

# The Mediating Role of Halal Awareness in Purchase Intention for Cosmetic Products: An empirical study in Klang Valley

Farida Bhanu Bt. Mohd Yousoof<sup>1</sup>, Komathi Munusamy<sup>2</sup>, Kalaivani Jayaraman<sup>3</sup>, Mahendra Kumar Chelliah<sup>4</sup>

<sup>1</sup>Faculty of Accountancy and Management, Universiti Tunku Abdul Rahman, faridabhanu@utar.edu.my

<sup>2</sup>Faculty of Accountancy and Management, Universiti Tunku Abdul Rahman, komathi@utar.edu.my

<sup>3</sup>Faculty of Accountancy and Management, Universiti Tunku Abdul Rahman, kalaivani@utar.edu.my

<sup>4</sup>Faculty of Accountancy and Management, Universiti Tunku Abdul Rahman, mahendra@utar.edu.my

Received: March 29, 2021; Accepted: April 15, 2021; Published: April 29, 2021

Cite This Article: Mohd Yousoof, F. B. B., Munusamy, K., Jayaraman, K., & Chelliah, M. (2021). The Mediating Role of Halal Awareness in Purchase Intention for Cosmetic Products: An empirical study in Klang Valley. *Journal of Progressive Research in Social Sciences*, 11(1), 22-32. Retrieved from <http://scitecresearch.com/journals/index.php/jprss/article/view/2039>

## Abstract.

Halal Trade has received much attention recently due to the increased Muslim population around the world. The rise of Muslim population has given much insights to the marketers as they present another concern in term of their consumption pattern. The religious belief required the Muslim to consume only the halal product. Hence, halal awareness becomes a determining factor for cosmetic product purchase among the Muslims. Current research paper studies the consumer's purchase intention through the mediating role of Halal awareness by adopting Theory of Planned Behaviour (TPB). The results revealed there are significant direct relationships between Attitude, Perceived Behavioural Control (PCB) and Subjective Norm towards Halal Awareness. Meanwhile, halal awareness is not mediating attitude-purchase intention relationship. The results explain that halal awareness influences the relationship between subjective norm, perceived behavioural control and purchase intention. This paper contributes by complementing existing research of the mediating role of halal awareness in TPB, particularly in cosmetic products.

**Keywords:** Halal Awareness; Purchase Intention; Cosmetics Products; Theory of Planned Behaviour.

## 1. Introduction

The progression of halal industries in Malaysia as well as other Muslims majority and minority countries are on the raising trend. (Bistari, 2004). Undeniably, the surge in the need of halal products globally rocketed in view of increase in both the Muslim population and their purchasing power (Aris & Rahman, 2011). According to Euromonitor's report (2008), it was stated that the Asian market is undeniably the fastest growing segments. The same report mentioned that, Asia Pacific region has reported as the second highest market for halal products after the Western European. In Malaysia, the Halal Master Plan which was introduced in 2008, highly supports halal integrity in process, implementation, and consumption. Moreover, the backing to this plan can be identified in the Third Industrial Master Plan (IMP3, 2006-2020) and the eleventh Malaysia Plan (2016-2020) (Bohari et al., 2013).

Muslim populations are obliged by their religion to use only halal products. In view of the religious requirement, muslim consumers tend to look for halal logos which are certified by religious authority in Malaysia that is Department of Islamic Advancement Malaysia (JAKIM) when purchasing their products. Even though, halal industry comprised larger market segment such as food, pharmaceuticals, cosmetics, packaging and logistics products. However majority of these products are manufactured from non-halal companies and many of these international brands may have been using enzymes obtained from pork or alcohol as preservatives (Vita et al., 2017). A research conducted by Ireland et al., (2011), revealed that consumer's uses halal products are highly committed to the halal brands. Adding to this findings, Abdul Aziz et al., (2013) claimed that some non-Muslim consumers also prefer to consume halal products in view of its safety as they perceived the halal image provides guarantees regarding quality of the food products.

The robust demand for halal cosmetics has inspired local firms such as Wipro Unza (Malaysia) Sdn Bhd., Southern Lion Sdn. Bhd., and SimplySiti Sdn. Bhd to get halal certification. Multinational corporations (MNC) such as Johnson & Johnson Sdn. Bhd. and Colgate-Palmolive's toothpaste and mouthwash brands have followed suit, and Japan's Shiseido Company has certified 28 halal products under its Za brand. South Korea's Talent Cosmetic Co. became the first Korean company to be halal-certified in Malaysia: 147 out of its 550 cosmetic products are now halal (Global Islamic Economy Gateway, 2017). Malaysia has embarked in implementing huge endorsement activities and programs to position itself as the Global Halal-Hub for Halal cosmetics and personal care products. To support these endeavour, many organisations like the Malay Chamber of Commerce Malaysia (MCCM) has decided to set up its marketing centre in Dubai. Furthermore, many retailers of Halal products participated in this events and it was estimated that over the next five years, more than \$10 billion worth of Halal products will be channelled through this market (Swidi et al., 2010).

Statistics show that 63.6% being in the age range of 15 years to 64 years. During the last few years, consumer spending on personal care products such as cosmetics and toiletries has gone up from RM1.4 billion in 1995 to RM1.9 billion in 2007. This has grew at a rate of more than 40% which indicates a surge in the cosmetic industry. In the current market, not only women, but men are also expected to create strong demand for personal care products. They believe that by using cosmetics will enhance their personal appearances. Therefore, it is expected that expenditure on personal care products to grow in near future as more new products being introduced into the market to a diversified consumers.

On the other hand, Halal certification and acceptance of Halal products had been well-known in the cosmetics and personal care industry by Muslim consumers. In addition, non-Muslim is no exemption in this regard (Ahmad et al. 2013). Furthermore, Golnaz et al. (2010) found that non-Muslims awareness of halal ideologies can be raised through advertisement published in halal products. They perceived that halal products are clean and pure from dirt and will not cause harm to them. Therefore, it is forecasted that the Halal cosmetics market share will be growing in an unexpected rate among the non-muslims in global market place. In a recent survey conducted by a consulting firm highlighted that although the level of awareness about Halal cosmetics is still at infancy stage, the consumers are ready to purchase Halal products if they are available. Moreover the consultants stressed that the level of awareness regarding Halal cosmetics is accelerating among the consumers of cosmetics products. In Malaysia, Zaitun group is the pioneer manufacturer and market leader of Halal cosmetics and captures a huge market share (Norafni et al., 2015). as disposable income growth slows over the coming years, many consumers may opt for less expensive products, dampening the growth of value sales. The level of awareness among consumers about the importance of Halal cosmetics is very much promising.

The importance of this study can be seen from two viewpoints. First the discussion about halal awareness as a mediator between subjective norms, attitude, perceived behavioural control in determining the purchase intention of halal cosmetics products in Malaysian context which is still limited, so this study can fill the gap in the literature. Second, this present study focuses on Kuala Lumpur and Selangor which has the largest number of working population. Due to the fact that the growth of middle class in these two states are flourishing, this research can form a basis which can be used to explore the huge potential. The purpose of the research is to provide an improved understanding of the nature of relationship between subjective norm, attitude and perceived behavioural dimensions that focus on Islam, as well as halal awareness as a mediator in purchase intention towards halal cosmetics products particularly amongst the muslim as well as non-muslim youth segment.

## 2. Literature Review

### 2.1 Purchase Intention

Intention to purchase can be referred as a preference of consumer's choice to either to purchase a products or service, (Younus, Rasheed & Zia, 2015). It is also claimed that a consumer's intention to purchase a product or services and as well evaluation might change after a purchase.

According to Haro (2016), a company sale is very much depended on consumer's purchase intention. In addition, purchase intention of consumer will be affected when consumers start selecting the preferences of products based on the multiple choices of product offered in the market (Keller, 2001; Younus et al., 2015). Hence, it's important to have a clear understanding on consumer's purchase intention from the marketing point of view.

Understanding the process of decision making towards purchase of a products or services by consumer considered to be a difficult task (Mirabi, Akbariyeh and Tahmasebifard, 2015). This is due to the influence of consumers purchase behaviour, perceptions and attitudes. Intention is the major aspect of Theory of Planned Behaviour (TPB). Ultimately, people's behaviour is reflected through their intention on the given behaviour (Haque, et al. 2018; Ajzen, 1991). Researcher argue that intention is one of the major factors create a driving force behaviour (Ajzen, 1991).

As of today, business market has grown rapidly competitive due to alternative products in the market which draw closer attention from consumer. It is important to understand consumer's expectation criteria when purchasing products and services.

## 2.2 Attitude

Attitude is better explained based on positive or negative evaluation by a person on something which they are unsure off, (Aziz, Noor & Wahab, 2013; Ajzen 1991). Furthermore, attitude found to bring significant impact in influencing consumers to purchase halal products, Alam & Sayuti, 2011; Aziz et al., 2013). In addition, attitude acts as an index of point where individual portrays their enjoyments or hatreds on an object as well carries favourable suggestions (Ajzen I & Fishbein M, 1980; Ali A, 2017).

Consumer may have many choices and from the choice given consumer uses their highest score of attitude evaluation to make their choice (Arvola, et al. 1999; Phuong & Dat, 2017). More to say, attitude react as or reviewed as of a certain behaviour that involve during purchasing of things (Blackwell et al. 2006; Alam et al., 2011). Overall behaviour is believed to link several assumptions and attribution to the attitude determination (Alam et al., 2011). The study of Alam et al. (2011) prove that changes of attitude can influence consumer's intention to purchase halal products.

Attitudes on the intention to purchase become positive as consumer started to accepting and recognizing the products (Ajzen, 1991; Rahim et al. 2012). A study was conducted and the result shows the purchase intention of halal products may change according to how one feels about the products (Afendi et al. 2014).

## 2.3 Subjective norms

Subjective norms is known as a person's view of social pressure for or against carrying out certain behaviour (Aziz, Noor & Wahab, 2013). It can also be explained as people's role in giving thoughts on certain behaviour and how people react towards the thoughts and beliefs (Miller, 2005; Omar, Mat, Imhemed & Ali, 2012).

According to Alam and Sayuti (2011), subjective norms is known as a pressure that a person perceive from the stand point of society and able to comply with the views of others would affects consumer's intention to perform certain behaviour. Hence, people's opinion surrounding the consumer influence individual behaviour. Subjective norms can influence people's choice in purchasing halal food (Alam et al. 2011). Collectivism culture consider themselves as mutually dependent with their group and less likely go to personal goals ( Alam et al, 2011). Malaysian citizen falls under collectivism as subjective norms affects their buying behaviour (Alam et al. 2011).

From Islamic culture perspective, Islam follows Prophet Muhammad's teaching on adapting admirable behaviour to his followers which brings many good effects on subjective norms (Rahim & Junos, 2012). Researchers also mentioned that if consumers were surrounded by important people, could bring the higher acceptable on halal products (Rahim et al., 2012). Aziz et al., (2013) discovered positive relationship between subjective norms and purchase intention. This is also supported by Afendi et al., (2014).

## 2.4 Perceived Behaviour control

Perceived behaviour control is picked from the component of Theory of Planned Behaviour. Perceived behavioural control showcases the readiness of consumers to do certain things (Ajzen et al.,1991; Alam & Sayuti,2011). It has been concluded that consumer has a power to decide the purchase of halal cosmetic.

Perceived behaviour control is believed to bring positivity towards the intention to purchase the products (Kim & Chung, 2011). Another study affirmed that perceived behaviour control affect purchase intention of someone (Alam et al., 2011). In addition, Son, Jin and George (2013), conducted research in India, found that there is a positive relationship between behavioural control and purchase intention.

Aziz, Noor and Wahab, (2013) has conducted research on halal cosmetic in Malaysia and the result shows that there is a positive connection between control a person has over buying a product with intention to buy. Comparatively, another research conducted in Indonesia by Haro (2016), proved that perceived behavioural control can positively influence the purchase intention. This research is also supported by another study conducted by Aishah (2016), stating that intention to purchase halal cosmetic will be affected by perceived behavioural control.

## 2.5 Halal Awareness

Halal awareness can be defined as the act of concern over something that is permissible in Islam (Noor Kamal & Mohammed, 2016). The word halal known to Islam as something permissible or products acceptable by Muslims under Shariah Law (Shaari & Arifin, 2010; Kamal et al., 2016). Halal awareness contributes significantly to the consumer's purchase intention (Kamal et al., 2016). It is important to Muslims to have some knowledge on how to indicate halal from non halal when testing a product (Yunus, Rashid, Arrifin & Rashid, 2014).

Nowadays people are more concern and careful when they make purchase as a consumer. As the consumer aware on the product that they intent to purchase (Ramadania, Putri & Juniwati, 2018). Consumer pays an interest on purchasing a product, but the important aspect before purchasing is that they are aware about the product prior the purchase. Awareness encompasses of human's perception and cognitive reaction to a condition or event (Machali, Abdullah & Razak, 2015). Awareness is not just about understanding but also about ability to be conscious, feel or perceived (Ramadania, Putri & Juniwati, 2018). More and more people concern about their products. It can be ranging from hygienically factors to halal, content and etc. Besides, peoples understanding on products shows a remarkable result on halal and green products. These two aspects can increase the awareness of a product and thus lead to the effects of purchase intention. Halal awareness can impact purchase intention of a consumer.

The research of halal awareness is supported by Aziz and Chok, (2013) where the research indicate that halal awareness has a positive relationship over intention to purchase. In addition, halal awareness plays an important role in consumer behaviour in purchasing of halal products (Zakaria, Majid, Ahmad & Zakaria, 2016). Reports in research also accepted that halal awareness has a positive effect on purchase intention. Al-hajla (2017), prove that there is a significant positive relationship towards purchase intention as when consumer knows and learn about halal products, that later will lead to the purchase of the products. Muslim with high intrinsic awareness will spent time to understand the concept of halal better (Hasibuan, Nasution & Angraini, 2017).

## 2.6 Theory of Planned Behaviour

Theory of Planned Behaviour (TPB) is one of the most well-known theories used to understand individual's behaviour and intention. This famous theory was developed by Ajzen in the year 1991. According to this theory, individual actual behaviour performed as a result of their intention. With this perception, people's behaviour has become the predecessor of their intention. Based on the TPB, individual intention made into three (3) factors. The first one is attitude, followed by subjective norms and perceived behavioural control (PBC). Attitude describe a person's favourable or unfavourable disposition towards a given object. Whereas subjective norms derived from social pressure and for PBC is the outcome of individual's control beliefs where it is said that individuals tend to perform their behaviour as they believe that they can control them.

## 3. Research Framework and Hypotheses Development

The above discussion has brought to the development of the following research framework.

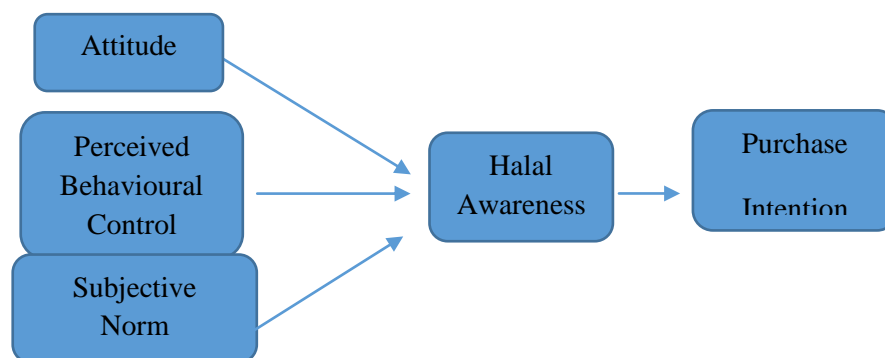

Figure 1: Research Framework

The following hypotheses are formulated in order to test the research framework illustrated in Figure 1.

H1 : There is a positive relationship between attitude and halal awareness.

H2: There is a positive relationship between perceived behavioural control and halal awareness.

H3: There is a positive relationship between subjective norm and halal awareness.

H4: Halal awareness mediates the relationship between attitude and purchase intention.

H5: Halal awareness mediates the relationship between perceived behavioural control and purchase intention.

H6: Halal awareness mediates the relationship between subjective norm and purchase intention.

#### 4. Methodology

The data was analysed by using Partial Least Squares Equation Modeling (PLS-SEM). PLS-SEM is considered as a soft modelling technique. As such it has emerged as the popular statistical analysis tools in recent years. PLS is capable to handle multicollinearity and many independent variables simultaneously because of its focus is prediction, not explanation (Garson, 2016). Therefore, prior knowledge of the relationships among independents and dependent is not a critical issue (Garson, 2016). Adding on, Cepeda-Carrion, Cegarra-Navarro, Cillo (2018) explained that another reason for using PLS-SEM is related to the nature of the construct. Often, the nature of the construct, i.e., “behavioural constructs” or “design constructs” could be easily identified (Henseler, 2017). “Behavioural construct” presence independently in the reality as ontological entity and it is associated to psychological characteristics (such as consumers’ attributes and/or attitudes). Henseler (2017) suggested that behavioural construct is probably modelled as a common factor. In current context, TPB Model is adopted and the moderator of Halal Awareness (HA) represent the consumers’ attributes. As such, PLSc is adopted as it produces the results that is mimic to Covariance based Structural Equation Modeling (CB-SEM). The following section present the results of the measurement model and structural model analysis.

##### 4.2 Measurement and assessment of the research variables

Two types of validity were being examined in assessing the measurement model - first the convergent validity and then the discriminant validity. The convergent validity of the measurement is determined by examining the loadings, average variance extracted (AVE) and also the composite reliability (Gholami et al., 2013; Rahman et al., 2015). The results are presented in Table 1. The loadings were all higher than 0.708, the composite reliabilities were all higher than 0.7 and the AVE of all constructs were also higher than 0.5 as suggested in the literature.

**Table 1**

Construct	Items	Loading	Cronbach's Alpha	rho_A	CR	AVE
Attitude	A1	0.866	0.935	0.935	0.949	0.755
	A2	0.899				
	A3	0.861				
	A4	0.879				
	A5	0.843				
	A6	0.863				
Halal Awareness	HA1	0.741	0.745	0.812	0.840	0.573
	HA3	0.808				
	HA4	0.913				
Perceived Behavioural Control	PCB1	0.775	0.841	0.862	0.891	0.672
	PCB2	0.792				
	PCB3	0.855				
	PCB4	0.841				
Purchase Intention	PI1	0.866	0.898	0.899	0.929	0.765
	PI2	0.898				
	PI3	0.857				
	PI4	0.877				
Subjective Norms	SN1	0.909	0.960	0.961	0.967	0.808
	SN2	0.931				
	SN3	0.828				
	SN4	0.899				

	SN5	0.902
	SN6	0.919
	SN7	0.901

The measurement model analysis is continued with the discriminant validity testing in the form of heterotrait-monotrait ratio of correlations. Henseler et al. (2015) added that HTMT method of assessing discriminant validity demonstrated superior performance by means of a Monte Carlo simulation study. Therefore, HTMT creation is adopted to test the discriminant validity and the results are shown in Table 2. If the HTMT value is greater than HTMT0.85 value of 0.85 (Kline 2011), or HTMT0.90 value of 0.90 (Gold et al., 2001) then there is a problem of discriminant validity. All the values shown in Table 2 passed the HTMT0.90 (Gold et al., 2001) and also the HTMT0.85 (Kline, 2011), indicating that discriminant validity has been ascertained.

**Table 2**

	Attitude	Halal Awareness	PCB	PI	Subjective Norm
Attitude					
Halal Awareness	0.742				
PCB	0.811	0.688			
PI	0.857	0.900	0.782		
Subjective Norm	0.855	0.762	0.681	0.773	

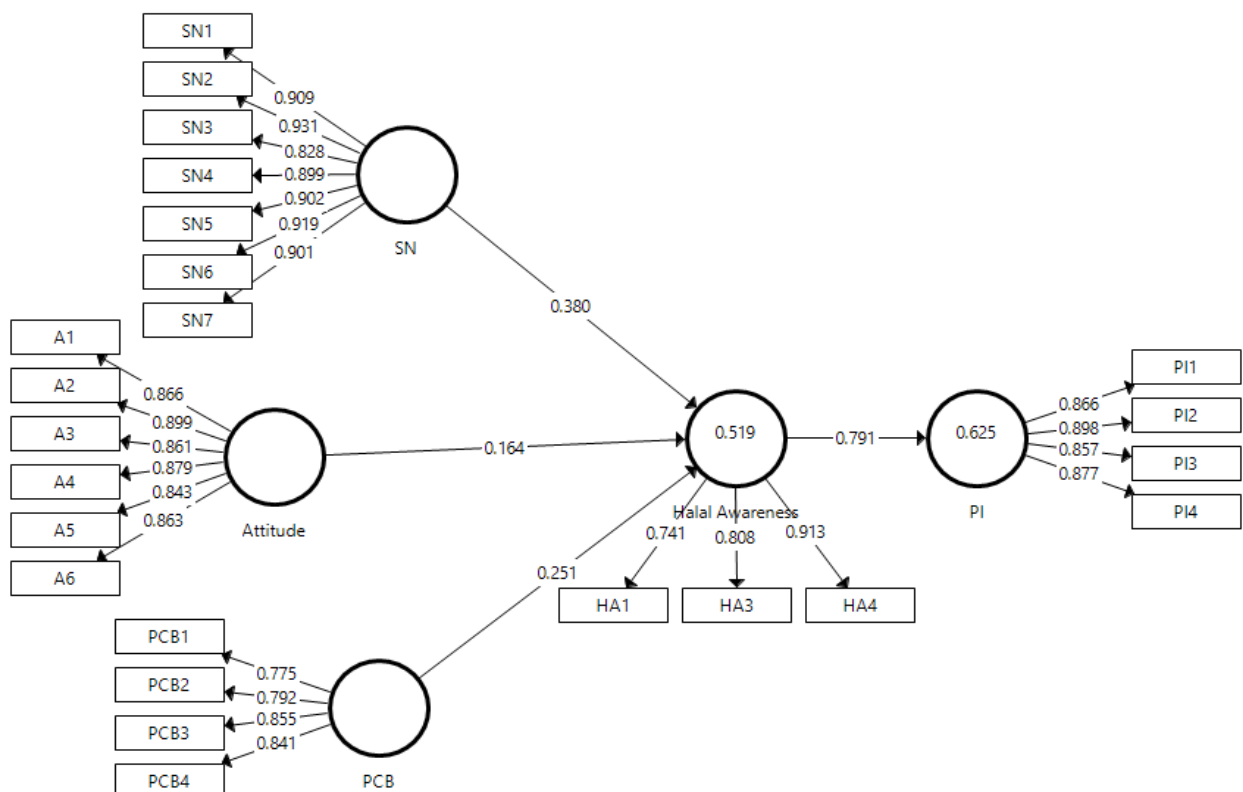

**Figure 2 : Measurement Model Result**

### 4.3 Structural Model

Before proceeding to test the research model, model fit is first being examined by Standardized Root Mean Square Residual (SRMR), Normed Fit Index (NFI) and exact model fit (bootstrapped based statistical inference). The research model in Figure 1 is deemed as a saturated model with no free paths, the saturated model (measurement) fit values and the estimated model (structural model) fit values were exactly the same. The SRMR value was 0.079 (< 0.08) and the NFI was 0.901 (> 0.90) and the dULS < bootstrapped HI 95% of dULS and dG < bootstrapped HI 95% of dG indicating the data fits the model well.

The analysis is then continued with structural model assessment, whereby Hair et al. (2017) suggested looking at the R<sup>2</sup>, beta (β) and the corresponding t-values via a bootstrapping procedure. The structural model assessment for all the direct relationships are reported in **Table 3**. In addition to these basic measures, the predictive relevance (Q<sup>2</sup>) and the effect sizes (f<sup>2</sup>) are also reflected in Table 3. The results informed that H2, H3 and H4 are supported while H1 is not supported.

**Table 3:** Hypothesis Testing for Direct Relationship Results

Hypothesis	Std. Beta	Std. Error	t-value	p-value	Decision	VIF	R <sup>2</sup>	Q <sup>2</sup>	f <sup>2</sup>
H1: Attitude -> Halal Awareness	0.164	0.168	0.771	0.221	Not Supported	3.175			0.009
H2: PCB -> Halal Awareness	0.251	0.117	2.685	0.004	Supported	2.797			0.102
H3: SN -> Halal Awareness	0.380	0.114	3.79	0.000	Supported	3.635	0.519	0.319	0.147
Halal H4: Awareness -> PI	0.791	0.03	30.695	0.000	Supported	1.000	0.625	0.449	0.557

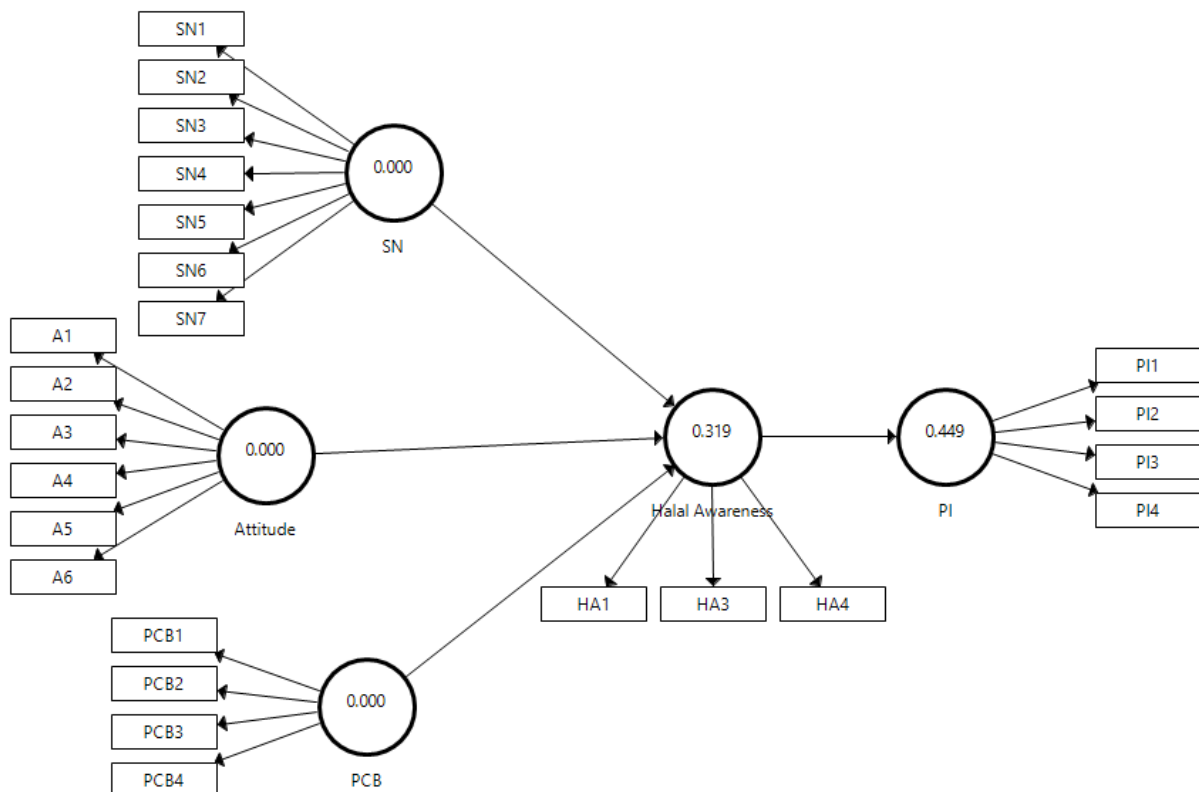

Figure 3: Blindfolding result

Table 4 presents the indirect relationships with Halal Awareness modelled as the mediator. The bootstrapping analysis shows that the indirect effect of Halal Awareness,  $\beta = 0.119$  was not significant at a t value of 0.765. Preacher and Hayes (2008) indicated that the indirect effect of 0.119, 95% Boot CI: [LL= -0.116, UL = 0.385] which straddle a zero value in between indicating that Halal Awareness does not mediate the relationship between Attitude and Purchase Intention. Therefore, H5 is not supported. Meanwhile, the bootstrapping analysis for the indirect effect of Halal Awareness,  $\beta = 0.290$  was significant at a t value of 2.606 with  $p < 0.05$  of PCB and Purchase Intention. Following, Preacher and Hayes (2008) indicated that the indirect effect of 0.290, 95% Boot CI: [LL= 0.118, UL = 0.489] which does not straddle a zero in between indicating that Halal Awareness mediates the relationship between PCB and Purchase Intention. As such, H6 is supported. As for H7, the indirect effect of Halal Awareness,  $\beta = 0.397$  was found to be significant at a t value of 3.804 based on the bootstrapping analysis. There is no zero value straddle between indicating that Halal Awareness mediates the relationship between SN and Purchase Intention (Preacher & Hayes, 2008). Hence, H7 is also supported.

**Table 4:** Hypothesis Testing for Indirect Relationship Results

Hypothesis	Std. Beta	Std. Error	T value	P value	5.0%	95.0%	Decision
H5: Halal Awareness mediates the relationship between Attitude and Purchase Intention	0.119	0.112	0.765	0.222	-0.116	0.385	Not Supported
H6: Halal Awareness mediates the relationship between PCB and Purchase Intention	0.290	0.301	2.606	0.004	0.118	0.489	Supported
H7: Halal Awareness mediates the relationship between SN and Purchase Intention	0.397	0.400	3.804	0.000	0.213	0.548	Supported

## 5. Discussion and Conclusion

The outcome of this study showed few interesting findings. Firstly, subjective norms are positively related to purchase intention of halal cosmetic products. This is similar to the findings of Miller, (2005), and Omar, et.al. (2012), which highlighted that, people play an important role in giving thoughts on certain behaviour and how in return people react towards the thoughts and beliefs. As such, family, friends, relatives, peers and others do play an important role in making purchase decisions. Secondly, the findings of this study also testifies that the significant relationship between perceived behavioural control and purchase intention shows that, consumers have a favourable attitude toward purchasing halal cosmetic products. This is probably, consumers believe that halal cosmetics would



be easily available and would like to buy it in future. The results is consistent with the findings of Son, Jin and George (2013) and Alam et al., (2011), where it was found that there is a positive relationship between behavioural control and purchase intention. For here, once again it is clear that perceived behaviour control is believed to bring positivity towards the intention to purchase the products (Kim & Chung, 2011). Lastly, the study supports that awareness act as a mediator between subjective norm-purchase intention relationship, and perceived behavioural control –purchase intention relationship. However, halal awareness is not a mediator in attitude-purchase intention relationship. The results explain that halal awareness influences the relationship between subjective norm and purchase intention as well as perceived behavioural control and purchase intention.

In conclusion, this study provides valuable insights for both cosmetics retailers and manufacturers. Attention should be given to ways that can create positive views towards halal cosmetics. Retailers and manufacturers should ensure that the cosmetics products that are produced do not have any human parts or ingredients nor containing any animals forbidden to Muslims. Moreover, manufacturers of cosmetics products should be aware that consumers will evaluate the quality of a product from their purchase experience as well as the experiences of their peers and relatives. With that, effective marketing strategies can be emphasised not only on ecological beauty or product safety but also towards the element of ‘halal’.

## References

- [1] Aishah M., (2016). Consumer Demand on Halal Cosmetics and Personal Care Products in Indonesia. *Journal of Islamic Economics*, 9(1), 125-142.
- [2] Ali A.,(2017). Halal Products Purchase Intention in Pakistan: Evidences from Non-muslim Community. *Arabian Journal of Business and Management Review*, 7(4).
- [3] Afendi, N. A., Azizan, F. L., & Darami, A. I. (2014). Determinants of halal purchase intention: Case in Perlis. *International Journal of Business and Social Research (IJBSR)*, 4(5), 118-123.
- [4] Ajzen, I. (1991). The theory of planned behavior. *Organizational behavior and human decision processes*, 50(2), 179-211.
- [5] Alam, S. S., & Sayuti, N. M. (2011). Applying the Theory of Planned Behavior (TPB) in halal food purchasing. *International Journal of Commerce and Management*, 21(1), 8-20.
- [6] Al-Hajla, A. (2017). Why do people purchase halal cosmetics? An integrated model on Saudi Arabia. *Journal of Arts, Science and Commerce*, 8(2), 22-34.
- [7] Aris, N.M., & Rahman, A.A .(2011). “Perlaksanaan dasar sekuriti makanan di Malaysia: kajian daripada perspektif ekonomi,” *Islam Shariah Journal*, 19(1), 39-62.
- [8] Arvola, A., Tourila H., & Lahtinmaki, L., (1999). Predicting the intent to Purchase unfamiliar and familiar Cheeses: The effects of Attitude, Expected Liking and Food Neophobia. Retrieved from: <https://www.researchgate.net/publication/13299387>
- [9] Aziz, A., Noor, N., & Wahab, E. (2013). Understanding of halal cosmetics products: TPB Model. UTHM Institutional Repository.
- [10] Aziz, Y. A., & Chok., N. V. (2013). The role of halal awareness, halal certification, and marketing components in determining halal purchase intention among non-muslims in Malaysia: A structural equation modeling approach. *Journal of International Food & Agribusiness Marketing*, 25(1), 1-23.
- [11] Bentler, P. M., & Bonett, D. G. (1980). Significance Tests and Goodness-of-Fit in the Analysis of Covariance Structures. *Psychological Bulletin*, 88, 588-600
- [12] Bistari, Z.M., (2004). Halal certification scheme, *Standard and Quality News*, 11(4), 1.
- [13] Blackwell, R.D., Miniard, P.W., Engel, F.J. (2006), *Consumer Behaviour*.
- [14] Mason: Thomson
- [15] Blackwell, R.D., Miniard, P.W., Engel, F.J. (2006), *Consumer Behaviour*. Mason: Thomson
- [16] Bohari, A.M.,W. H. Cheng, and N. W. Fuad.(2013). An analysis on the competitiveness of halal food industry in Malaysia: an approach of SWOT and ICT strategy, *Malaysia Journal of Society and Space* , 9(1), 1-11.
- [17] Briliana.V & Mursito, N.(2017). Exploring antecedents and Consequences of Indonesian Muslim Youths’ Attitude Toward Halal Cosmetics Products: A Case Study in Jakarta, *Asia Pacific Management Review*, 22, 176-184.

- [18] Fishbein, M. / Ajzen, I. (1975): *Belief, attitude, intention and behaviour: An instruction to theory and research*: Addison-Wesley.
- [19] Gabriel Cepeda-Carrion, Juan-Gabriel Cegarra-Navarro, Valentina Cillo, (2018) "Tips to use partial least squares structural equation modelling (PLS-SEM) in knowledge management", *Journal of Knowledge Management*, <https://doi.org/10.1108/JKM-05-2018-0322>
- [20] Garson, G. D. (2016). *Partial least squares: Regression and structural equation models*. Asheboro, NC: Statistical Associates Publishers.
- [21] Gholami, R., Sulaiman, A. B., Ramayah, T., & Molla, A. (2013). Senior managers' perception on green information systems (IS) adoption and environmental performance: Results from a field survey. *Information and Management*, 50(7), 431-438.
- [22] Global Islamic Economy Gateway(2017): Malaysia halal cosmetics: Looking good at home and stepping out abroad. Retrieved April 20, 2019 from [www.salaamgateway.com/en/story/malaysia\\_halal\\_cosmetics\\_looking\\_good\\_at\\_home\\_and\\_stepping\\_out\\_abroad-SALAAM03042017055404/](http://www.salaamgateway.com/en/story/malaysia_halal_cosmetics_looking_good_at_home_and_stepping_out_abroad-SALAAM03042017055404/)
- [23] Gold, A. H., Malhotra, A., & Segars, A. H. (2001). Knowledge management: an organizational capabilities perspective. *Journal of Management Information Systems*, 18(1), 185–214.
- [24] Haro, A. (2016). Understanding TPB model, availability, and information on consumer purchase intention for halal food. *International Journal of Business and Commerce*, 5(8), 47-56.
- [25] Hasibuan, H. A., Nasution, M. D., & Anggraini, F. (2017). The effect of halal label, halal awareness and brand image on consumer intention to buy. *International Journal for Innovative Research Multidisciplinary Field*, 3(11), 140-147.
- [26] Haque, A., Anwar, N., Yasmin, F., Sarwar, A., Ibrahim, Z., & Momen, A. (2015). Purchase intention of foreign products: A study on Bangladeshi consumer perspective. SAGE, 1–12. Doi:10.1177/2158244015592680
- [27] Haque.A and Sarwar.A(2015). Non-Muslim consumers' perception toward purchasing halal food products in Malaysia, *Journal of Islamic Marketing*, 6(1), 133-147.
- [28] Henseler, J. (2017), "Bridging design and behavioral research with variance-based structural equation modeling", *Journal of Advertising*, 46 (1), 178-192, available at: <https://doi.org/10.1080/00913367.2017.1281780>
- [29] Hu, L.-T., & Bentler, P. M. (1998). Fit Indices in Covariance Structure Modeling: Sensitivity to Underparameterized Model Misspecification. *Psychological Methods*, 3(4), 424-453
- [30] Ireland, J., & Rajabzadeh., S.A.(2011). UAE, consumer concerns about halal products, *Journal of Islamic Marketing*,2(3), 274-283.
- [31] Keller, K. L. (2001). Building Customer-Based Brand Equity: A Blueprint for Creating Strong Brands. *Marketing Management*, 10(2), 14-19.
- [32] Kim, H. Y., & Chung, J. E. (2011). Consumer purchase intention for organic personal care products. *Journal of Consumer Marketing*,28(1), 40-47.
- [33] Kline, R. B. (2011). *Principles and practice of structural equation modeling*. New York: Guilford Press.
- [34] Machali, M.M., Abdullah,R., & Razak, L.A. (2015).The effect of halal foods awareness on purchase decision with religiosity as a moderating variable. Retrive April 2019 from : <https://www.researchgate.net/publication/288701861>
- [35] Miller, P., Plant, M. & Plant, M. (2005). Spreading out or concentrating weekly consumption:
- [36] Alcohol problems and other consequences within a UK population sample. *Alcohol & Alcoholism*, 40, 461–468.
- [37] Mirabi, V., Akbariyeh, H., & Tahmasebifard, H. (2015). A study of factors affecting on customers purchases intention. *Journal of Multidisciplinary Engineering Science and Technology (JMEST)*,2(1), 267-273.
- [38] Noor Kamal, N.S. & Mohammed A.A. (2016). Factors Influencing Consumer's Intentions Towards Purchasing Islamic Hotel Service: A Conceptual Model. *Prosiding Pengurusan Halal, Ekonomi and Perniagaan*, Perpustakaan Sultanah Bahiyah UUM.

- [39] Norafni, B.R., Shafii, Z. & Shahwan, S., (2015). Awareness and Perception of Muslim Consumers on Halal Cosmetics and Personal Care Products. *International Journal of Business, Economics and Management* 2 (1), 1-14.
- [40] Omar, K. M., Mat, N. K., Inhamed, G. A., & Ali, F. M. (2012). The direct effects of halal product actual purchase antecedents among the international muslim consumers. *American Journal of Economics*, 87-92.
- [41] Phuong N.N.D., & Dat N.D., (2017). The Effect of Country of origin on Customer Purchase Intention: A study on Functional Products in Vietnam. *Journal of Asian Finance, Economic and Finance*, 4(3), 75-83.
- [42] Rahim, N. A., & Junos, S. (2012). The halal product acceptance model for the religious society. *Business & Management Quarterly Review*, 3(1), 17-25.
- [43] Rahim, F., Shafii, Z., & Shahwan, S. (2015). Awareness and perception of Muslim consumers on halal cosmetics and personal care, *International Journal of Business, Economics and Management*, 2(1), 1-14.
- [44] Rahman, S. A., Amran, A., Ahmad, N. H., & Taghizadeh, S. K. (2015). Supporting entrepreneurial business success at the base of pyramid through entrepreneurial competencies. *Management Decision*, 53(6), 1203-1223.
- [45] Ramadania, Putri, E.O., & Juniwati (2018). Intention Toward Halal and Organic Food: Awareness for Natural Content, Religiosity, and Knowledge Context. Retrieved from: <https://knepublishing.com/index.php/Kne-Social>
- [46] Samori, Z. and Sabtu, N. (2014). Developing Halal Standard for Malaysian Hotel Industry: An Exploratory Study, *Procedia-Social and Behavioral Sciences* pp.144-157.
- [47] Shaari, J. A. N., & Mohd Arifin, N. S. (2010). Dimension of halal purchase intention: A preliminary study. *International Review of Business Research Papers*, 6(4), 444-456.
- [48] Son, J. H., Jin, B. H., & George, B. (2013). Consumers' purchase intention toward foreign brand goods. *Management Decision*, 51(2), 434-450. Retrieved November 25, 2018, from <https://doi.org/10.1108/00251741311301902>.
- [49] Swidi A., Cheng, W., Hassan MG, Hosam, A.A.L. & Kassim, M., (2010). The mainstream cosmetics industry in Malaysia and the emergence, growth, and prospects of halal cosmetics. *The Third International Conference on International Studies (ICIS)*, 1-20. ISBN 9789832078456.
- [50] Younus, S., Rasheed, F., & Zia, A. (2015). Identifying the factors affecting customer purchase intention. *Global Journal of Management and Business Research: A Administration and Management*, 15(2), 8-13.
- [51] Yunus, N. N., Rashid, W. E., Ariffin, N. M., & Rashid, N. M. (2014). Muslim's purchase intention towards non-muslim's halal packaged food manufacturer. *Procedia- Social and Behavioral Science*, 145-154.
- [52] Zakaria, Z., Majid, M. A., Ahmad, Z., Jusoh, Z., & Zakaria, N. (2016). Influence of halal certification on customers' purchase intention. *Journal of Fundamental and Applied Sciences*, 589-600.