



Improving the MVA-km Method for Transmission Cost Allocation Using Counter-Flow Approaches

Ali Mokhtarizadeh ¹, Alireza Sedaghati ²

¹ Shahab-Danesh Institute of Higher Education, MS. Student in Electrical Engineering,

² Shahab-Danesh Institute of Higher Education, PhD in Electrical Engineering.

Abstract.

Today with restructuring in power systems and the emergence of competitive electricity markets, operation of the power system have been many changes one of the challenges facing the electricity markets, is transmission pricing. transmission pricing has great impact on the network return on investment, competition and attracting new investors. In this paper, transfer pricing is performed by combination of Zbus and MVA-km methods. The Zbus method is used to determine the contribution of participant of lines transmission power and MVA-km method is used to determine the cost of participant transmission. Lines average apparent power flow is used in MVA-km method. three approaches to using MVA-km is defined in order to investigate the effect of reverse power of lines and how to calculate costs is presented by each approach. Simulation of the proposed method on the test network of 12 Bass is done. and the results of MW-km is compared with MVA-km. also, the results of these three approaches of MVA-km method were compared together and analysis their advantages and disadvantages.

Keywords: Electricity markets; network transmission; transmission pricing; MW-km method; MVA-km method; Zbus method;

1. Introduction

In recent years, restructuring power systems and the emergence of competitive electricity markets around the world create the clear differences on operation of power systems. One of the most important characteristics of electricity markets is the technical characteristics of the transmission network, compared with other markets. accepted producers of market, are required to use the network transmission for transmission the productive power to consumers. Therefore, open access to network transmission plays an important role in the competitive electricity market [1, 2].

One of the most important challenges in the electricity market is the allocation of costs of the transmission network between market players [3]. In the electricity market, the productive power can't deliver consumer through specific path, due to the technical characteristics of the transmission network and the theory of electrical circuits, it's not possible to deliver consumer, productive power from a specific path, but in the transmission network, the production power of a network inject by manufacturer and it is picked up from the other side, by the consumer and meanwhile, all of the other powers of production and consuming, can affect the exchange. In other words, passing power of transmission lines don't follow the markets financial laws, but follow the laws of load flow [2]. Due to this theme, determine the transmission network pricing mechanism, is required the specific characteristics of the electricity industry. Transmission pricing plays a significant role in the presentation of correct economic information, network utilization and capacity of existing network. Also the transfer pricing plays an important role to enhance and develop the transmission network in future investment. An appropriate mechanism for transfer pricing, may cause optimal resource allocation in the network, in long-term [3, 4]. Transfer pricing mechanism should pursue the following objectives [5]:

- To compensate the cost of transmission system and expected income of investors of transmission system.
- Fair and equitable division of costs between all subscribers transfer system
- Improve and increase economic efficiency of network

Up to now various methods is provided for transfer pricing in electricity markets. References [6-9] have conducted a review of types of the network pricing. These methods fit in two general categories: "incremental cost transmission pricing (marginal)" and " embedded cost transmission pricing ". incremental cost transmission pricing (marginal), are methods which to transition pricing, consider only short-term (operational) network [8]. This category includes nodal pricing method, [10,11], zonal method [12,13] and regional method [9]. in nodal pricing method, the electricity market settlement is done by using locational marginal pricing method and for this reason, market price of electricity on different buses of system will vary each other. the difference is the base of transition pricing, in the nodal method. On zonal and regional pricing methods, transition pricing is done based on the difference in energy prices between zones and regions in the system. on embedded cost transmission pricing methods, the costs of long-term (investment) of network is considered for transition pricing [8]. this category includes pricing methods such as, postage stamp [14], contract path [1,15], MW-Mile or MW-km, power distribution coefficients[18] and Zbus [19]. In the postage stamp method, based on investment costs of the network, is received a fixed and same fee of all participant. In the contract path, a financial path is considered for flowing the power in the network and accordingly, the cost of using the network is calculated. In the MW-mile method, the contribution of each of the participant from the active power flow through any of the lines is calculated using dc load flow calculations and accordingly, the allocation of the costs of the transition network are done. The principles of methods of power distribution coefficients and Zbus MW-mile are similar, Principles and methods of power distribution coefficients Zbus MW-mile method is similar, with the difference that in the method of power distribution coefficients for calculating the contribution of the participants from lines power flow is used " Generation Power Shift Distribution Coefficients » (GSDF) and in Zbus method, is used the theory of electrical circuits and network impedance matrix.

The transmission pricing mechanism addition to ensuring the return of all costs of the transmission network, it must distribute costs between network subscribers fairly. Some methods, such as the postage stamp method, even though satisfy all the costs of the transmission network, but the costs are distributed between network subscribers, unfairly, because don't consider the location of the participant in the network and their distance from the centers of production and power consumption. On the other hand, it is possible that some methods such as nodal pricing method, with fairness, receive the cost of network subscribers much more or less than the actual cost of the transmission network. From another point of view, disadvantage of more transmission pricing methods is that only lines active power flow are considered in pricing, while the lines reactive power flow, have an important role in occupying of line capacity and congestion on the transmission lines [20]. In the meantime, just MVA-km method and Zbus method consider the lines reactive power flow. The MVA-km method is similar to MW-km, with the difference that the reactive power consider in calculation of transmission cost in MVA-km method [8]. in this method the results are low accuracy because the laws governing the load flow is considered to be linear. Although Zbus method calculates contribution of each participant of active and reactive power, as well, but on calculation of the cost of transmission method, does not consider the difference between sent and receive lines power and the counter-flow powers role [21, 22]. In this article, the cost allocation of using of the transmission network performs using MVA-km improved method. In the proposed method on this article to calculate contribution of network participants from lines flow powers, use the Zbus method, to obtain more accurate responses. The average amount of sent and received line powers is used to calculate the transmission costs. Also, three approaches are defined for MVA-km method according to the inverse powers of the network and mathematical relationships of calculating cost will present for each of the approaches. The rest of this article is as follows: In the second section, will express how to calculate the participant contribution of the network lines power flow by Zbus method and how to calculate costs by MVA-km method. The proposed approaches for calculating the cost of transmission by MVA-km method are introduced in the third section. A case study was done on test network of 12 bus and are analyzed the results in the fourth section. The results are presented in the fifth section.

2. Allocation of transmission costs by the combination of Zbus and MVA-km methods

2.2. Zbus method

In current section, with using Zbus method, the contribution of each participant is calculated in the network lines power flow. In Zbus method, π equivalent circuit used for network modeling. π equivalent circuit shown in Figure 1. apparent power flow of j-k transmission line that is caused by an injection of current in the network i bus is calculated as follow [21,22]:

$$S_{jk}^i = U_j \cdot I_{jk}^{i*} \quad (1)$$

S_{jk}^i : j-k line apparent power flow from j-bus to k-bus resulting of current injection in the i-bus

U_j : the voltage of j-bus

I_{jk}^i : current flow of j-k line from j-bus to k-bus resulting of the injection at i-bus

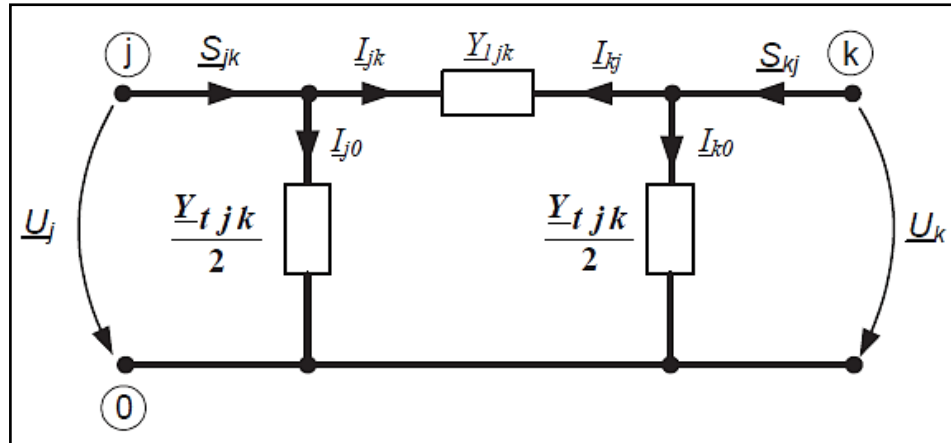

Figure 1. π equivalent circuit of j-k line

Note: the asterisk * means conjugate of complex number

Using mathematical equations that are presented in [21, 22]:

$$I_{jk}^i = D_{jk}^i \cdot I_i \quad (2)$$

$$D_{jk}^i = (Z_{ji} - Z_{ki}) \cdot Y_{ljk} + Z_{ji} \cdot \frac{Y_{tjk}}{2} \quad (3)$$

I_i : injected current in the i-bus

D_{jk}^i : electrical distance between i-bus and j & k-buses

Z_{ji} : elements of j row and i column of network impedance matrix

Z_{ki} : elements k row and i column of network impedance matrix

Y_{ljk} : admittance of transmission line j-k

Y_{tjk} : susceptance of entire of transmission line

Now, by substituting equation (2) in (1), apparent power flow through the jk line resulting of the injection in the i bus is obtained as follows:

$$S_{jk}^i = U_j \cdot D_{jk}^{i*} \cdot I_i^* \quad (4)$$

By substituting D_{jk}^{i*} in (4), flowing active and reactive power through the jk line from j to k, resulting of power injection in i bus is calculated as follows. In the presented equations in [21, 22], instead the I_i^* in equation (4), $\frac{S_i^*}{U_i^*}$ is placed in the wrong way. Because according to general equation $S_i = U_i I_i^*$, proper equivalent of I_i^* is equivalent $\frac{S_i}{U_i}$. This bug is removed in the following equations:

$$P_{jk}^i = Re \left\{ U_j \cdot \left[(Z_{ji}^* - Z_{ki}^*) \cdot Y_{ljk}^* + Z_{ji}^* \cdot \frac{Y_{tjk}^*}{2} \right] \cdot \frac{S_i}{U_i} \right\} \quad (5)$$

$$Q_{jk}^i = Im \left\{ U_j \cdot \left[(Z_{ji}^* - Z_{ki}^*) \cdot Y_{ljk}^* + Z_{ji}^* \cdot \frac{Y_{tjk}^*}{2} \right] \cdot \frac{S_i}{U_i} \right\} \quad (6)$$

$$P_{kj}^i = Re \left\{ U_k \cdot \left[(Z_{ki}^* - Z_{ji}^*) \cdot Y_{ljk}^* + Z_{ki}^* \cdot \frac{Y_{ljk}^*}{2} \right] \cdot \frac{S_i}{U_i} \right\} \quad (7)$$

$$Q_{kj}^i = Im \left\{ U_k \cdot \left[(Z_{ki}^* - Z_{ji}^*) \cdot Y_{ljk}^* + Z_{ki}^* \cdot \frac{Y_{ljk}^*}{2} \right] \cdot \frac{S_i}{U_i} \right\} \quad (8)$$

P_{jk}^i : jk line active power flow from j-bus to k-bus resulting from flow injection in the i-bus

Q_{jk}^i : jk line reactive power flow from j-bus to k-bus resulting from flow injection in the i-bus

Using the equations (5) to (8), the amount of sent and received active and reactive power from each of the network lines, caused by power injection can be calculated on each of the network buses. Thus, the share of each buses of network in the lines power flow is calculated. The S_i represents injected net power at bus number i. Production net power in each bus equal to the production power minus the consumption power of the bus.

2.3. - MVA-km method

In the MVA-km method, the amount of MVA-km of power flow that are made by each participant in each of the lines of network, is calculated from multiplying the apparent power flow that is created by the participant by the length of that line. Then in order to calculate transmission cost in the line for the participant, this amount multiplying by the cost of transmission capacity unit.

Because of the losses of reactive and active then, sent and received reactive and active powers, are not similar. Then, on this article, unlike previous researches, to calculate the costs of transmission use the lines average apparent power flow. The j-k line apparent power flow of, resulting of the injected power in i-bus is calculated by the following equation:

$$\hat{S}_{jk}^i = \sqrt{(\hat{P}_{jk}^i)^2 + (\hat{Q}_{jk}^i)^2} \quad (9)$$

\hat{S}_{jk}^i : j-k line average apparent power flow of resulting from flow injection in the i-bus

\hat{P}_{jk}^i : j-k lines average apparent active power resulting from power injection in the i-bus

\hat{Q}_{jk}^i : j-k lines average apparent reactive power resulting from power injection in the i-bus

Also, the average power flow and reactive powers of lines are calculated from following equations:

$$\hat{P}_{jk}^i = \frac{P_{jk}^i - P_{kj}^i}{2} \quad (10)$$

$$\hat{Q}_{jk}^i = \frac{Q_{jk}^i - Q_{kj}^i}{2} \quad (11)$$

The parameter P_{jk}^i , Q_{jk}^i , P_{kj}^i and Q_{kj}^i , are calculated from equations (5) to (8). The reason of negative mark on up equations is the sent and received lines average power, have opposite sign each other. With lines apparent power flow resulting from power injection in the i-bus, obtained the total costs allocated to the participant on the i-bus by the following equation:

$$C_i = \sum_{n=1}^N T_n \cdot L_n \cdot \hat{S}_n^i \quad (12)$$

C_i : the allocated costs to the participant in i-bus (\$)

n: counter of lines of network

N: total number of lines of network

T_n : the base cost of n-th transmission line (\$/MVA.km)

L_n : the length of n-th transmission line (km)

\hat{S}_n^i : the average apparent power flow of n-th transmission line resulting from power injection in i-th bus (MVA).

3. Proposed methods for calculating the cost of transmission by counter flow approaches

In the previous section, how to calculate the allocated costs to each of the participant was shown by the combination of Zbus and MVA-km methods. As it was seen in MVA-km conventional method for calculating the cost of transmission, in equation (12), the of the line apparent power flow average amount was used. In a power system, lines average power flow caused generation or consumption of power by participants, may be in opposite direction to each other, always. In these conditions, power flow share of one participant of one line may neutralize power flow share of another participant and thus reduce net power flow of transmission line and will increase power transmission capacity of line. If the power flow share of a participant from one line be opposite direction of line net power flow, that named " counter power ". In [14, 23], based on the lines counter power, three different approaches introduced for MW-km method: since the MVA-km method, unlike MW-km method, is considered active and reactive power simultaneously, it is needed to improve the MVA-km method, according to the lines counter power. In this section as an innovation, proposed method for taking into account the lines counter power in the calculation of costs by MVA-km method are presented, in three approaches, as below:

3.1. Absolute MVA-km approach

In this approach, the transmission costs is calculated regardless of the power direction of transmission lines, based on the absolute amount of MVA-km of each of the network participants. Thus, for each of transmission lines, by substituting of participant share in lines apparent power flow (\hat{S}_{jk}^i), in equation 12, the cost of transmission will calculate and cash out the participant.

3.2. Reverse MVA-km approach

In this approach, the costs of transmission will be counted, based on, the net amount of lines apparent power flow. Also those participants who cause power flow that opposing main power of lines and thereby, reduce the lines net power flow, they will be charged for this work. In this approach, four modes may occur:

Mode 1: the participant share of lines active and reactive powers, is in the same direction of line active and reactive power flow. In this mode, the costs are calculated and are cashed out from the participant by substituting the participant share in the lines apparent power flow \hat{S}_{jk}^i , in equation (12).

Mode 2: the share of participant in lines active and reactive powers, is opposite direction of line active and reactive powers flow. In this mode, the costs are calculated and are paid the participant by substituting the participant share in the lines apparent power flow \hat{S}_{jk}^i , in equation (12).

Mode 3: the share of participant in active power is same direction by line active power and the share of participant in reactive power is opposite direction of lines apparent power flow. In this mode, the cost of transmission of active power is calculated and is cashed out from the participant by substituting the participant share in the lines active power flow of \hat{P}_{jk}^i , in equation (12). Also, cost of transmission of reactive power is calculated and is paid the participant, by substituting the participant share in the lines reactive power flow of \hat{Q}_{jk}^i , in equation (12).

Mode 4: the share of participant in reactive power is same direction of line active power and the share of participant in active power is opposite direction of line average apparent power flow. In this mode, the cost of transmission of active power is calculated and is paid to the participant by substituting the participant share in the lines apparent power flow \hat{P}_{jk}^i , in equation (12). Also, cost of transmission of reactive power is calculated and is cashed out from the participant, by substituting the participant share in the line reactive power flow \hat{Q}_{jk}^i , in equation (12).

3.3. Zero counter-flow MVA-km approach

In this approach, the transmission costs are calculated based on the net amount of lines apparent power flow. In this approach, unlike absolute MVA-km approach, the participants who caused the counter power in the network, do not pay cost for using the network. On the other hand, unlike inverse MVA-km approach, do not pay any cost to this category of participants for this counter power. In this approach, four modes may occur:

Mode 1: the participant share of line active and reactive powers, is same direction of line active and reactive powers flow. In this mode, the cost of transmission is calculated and is cashed out from the participant, by substituting the participant share in the lines apparent power flow \hat{S}_{jk}^i , in equation (12).

Mode 2: the share of participant in lines active and reactive powers, is opposite direction of line active and reactive powers. In this mode, no cost is paid to the participant or is cashed out from participant for transmission.

Mode 3: the share of participant in active power is same direction by line active power and the share of participant in reactive power is opposite direction of line reactive power flow. In this mode, the cost of transmission of active power is calculated and is cashed out from the participant by substituting the participant share in the lines active power flow \hat{P}_{jk}^i , in equation (12). Also, no cost is paid or cashed out for transmission of reactive power.

Mode 4: the share of participant in reactive power is same direction of line active power and the share of participant in active power is opposite direction of line reactive power. In this mode, no cost is paid or cashed out for participant for transmission of active power. the cost of transmission of reactive power is calculated and is cashed out from the participant, by substituting the participant share in the lines active power flow \hat{Q}_{jk}^i , in equation (12).

In the future section, these three approaches have been tested on the test network and the results are compared each other.

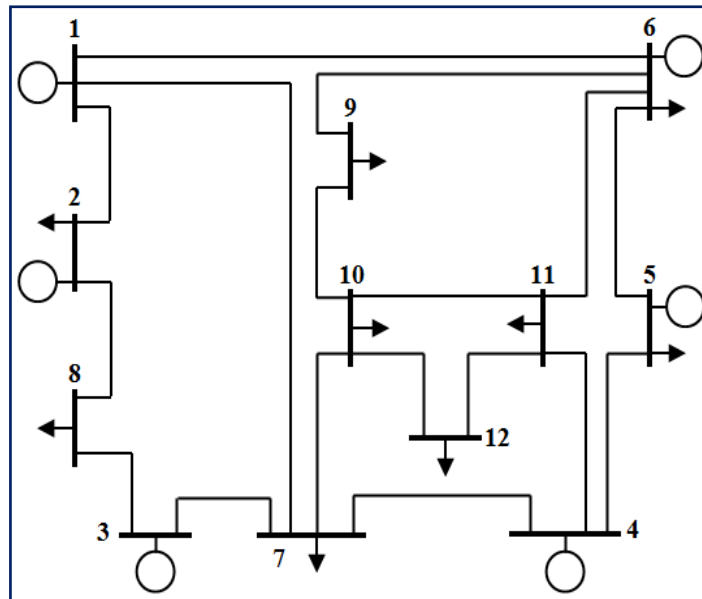

Figure 2. Single-line diagram of test network of 12 bus

Table1. The information of test network buses of 12 bus

Consumption active power (MW)	Consumption active power (MW)	Productive reactive power (MW)	Productive active power (MW)	Voltage angle (deg)	Amount of voltage (p.u.)	Type of the bus	Number of the bus
0	0	-	-	0	1.05	slack	1
35	300	-129.38	375.56	-	1	PV	2
0	0	13.43	350	-	1	PV	3
0	0	40.51	303.71	-	1	PV	4
25	350	-15.71	600	-	1	PV	5
60	230	125.73	200	-	1	PV	6
38	350	0	0	-	-	PQ	7
25	300	0	0	-	-	PQ	8
30	208	0	0	-	-	PQ	9
20	170	0	0	-	-	PQ	10
23	210	0	0	-	-	PQ	11
15	130	0	0	-	-	PQ	12

4. Case study

4.1. Information of test network

In this section, simulation of proposed method is done for calculating the cost of transmission on 12 bus sample network. Its network diagram is shown in figure 2. This network has 6 generators and 17 transmission line. Information of buses and lines of the network, are taken of references [21, 22], are presented on table 1 and table 2, respectively. The amount of T_n (the base cost of n-th transmission line) that is used in equation 12 is considered 2\$/MVA-km for all of lines, according to reference [21].

Table 2. The information of test network lines of 12 bus

The length of line (km)	The susceptances of line (p.u.)	The reactance of line (p.u.)	Line resistance (p.u.)	End bus	Initial bus	Number of line
30	0.04	0.025	0.00415	2	1	1
70	0.0949	0.05838	0.00969	6	1	2
120	0.16132	0.1	0.0166	7	1	3
30	0.04	0.025	0.00415	8	2	4
38	0.0511	0.03169	0.00526	7	3	5
45	0.06	0.03752	0.00623	3	8	6
60	0.08	0.05	0.0083	4	5	7
28	0.03765	0.02335	0.00387	4	7	8
60	0.08	0.05	0.0083	11	4	9
40	0.05379	0.03335	0.00554	5	6	10
30	0.02	0.0125	0.002075	9	6	11
50	0.06725	0.0417	0.00692	11	6	12
40	0.05379	0.03335	0.00554	7	10	13
20	0.0269	0.01667	0.00277	10	9	14
50	0.06725	0.0417	0.00692	11	10	15
34	0.047	0.02912	0.00484	12	10	16
25	0.0336	0.0208	0.00346	12	11	17

Simulation of the proposed method by software package of matpower5.1 in MATLAB software environment is done. On this software for load flow of ac, is used the Newton - Raphson method [24].

4.2. Results of ac load flow

In this section, ac load flow results are presented on the test network. The related results to network buses are presented in table 3 and the related results to network lines are presented in table 4.

Table 3. The information of buses of test network from load flow results

Consumption reactive power (MW)	Consumption active power (MW)	Productive reactive power (MW)	Productive active power (MW)	Voltage angle (deg)	Amount of voltage (p.u.)	Number of the bus
0	0	290.05	443.43	0	1.05	1
35	300	-129.38	375.56	-1.16	1	2

0	0	13.43	350	-1.48	1	3
0	0	40.51	303.71	-3.67	1	4
25	350	-15.71	600	-2.40	1	5
60	230	125.73	200	-6.44	1	6
38	350	0	0	-5.85	0.99055	7
25	300	0	0	-3.87	0.98837	8
30	208	0	0	-8.36	0.98742	9
20	170	0	0	-8.97	0.98195	10
23	210	0	0	-8.96	0.98207	11
15	130	0	0	-9.89	0.97783	12

Table 4. The information of test network lines from load flow results

Reactive power of end of line (MVAR)	Reactive power of initial of line (MVAR)	Active power of end of line (MW)	Active power of initial of line (MW)	End bus	Initial bus	number of line
-182.11	189.30	-114.67	116.56	2	1	1
-44.44	60.74	-208.39	212.75	6	1	2
-42.83	40.01	-111.80	114.12	7	1	3
-12.19	17.38	-188.72	190.23	8	2	4
16.02	-3.14	-234.94	237.92	7	3	5
11.67	-12.81	112.08	-111.28	3	8	6
3.65	-10.69	-43.10	43.26	4	5	7
14.52	-11.93	163.72	-162.68	4	7	8
-0.80	9.80	-180.29	183.09	11	4	9
-29.58	38.70	206.74	-204.33	5	6	10
-50.56	58.47	-273.25	274.89	9	6	11
-25.44	24.00	-106.98	107.83	11	6	12
0.74	2.66	159.41	-157.98	7	10	13
-22.36	20.56	-65.11	65.25	10	9	14
-3.06	-3.43	0.67	-0.67	11	10	15
-6.75	3.12	-53.61	53.76	12	10	16
-8.25	6.30	-76.39	76.60	12	11	17

Using of obtained information from the load flow and by equations (5) to (8), will obtain the share of each of the network participants of active and reactive powers of initial and end of network lines. For this purpose, according to the method that is used in the reference [21], it is assumed that each of the participants, are placed in a buses of network. Thus, in the studied test network, there are 12 participants that each of them are placed on one of the buses 1 to 12. Because of huge amount of resulting for share of network participants in lines active and reactive powers flow, it is ignored presenting these results, on this article.

4.3. The comparison of the results of calculating the cost of transmission by using MW-km and MVA-km methods

In this section transmission cost of market participants calculates and compares using MW-km and MVA-km methods. For the use of MVA-km method, is used absolute MVA-km approach because the results be comparable with MW-km method. Allocated transmission costs to each of the participants in the network buses are shown on table 5 and figure 3.

Table 5. The allocated transmission cost to network participants by absolute MW-km and MVA-km methods

Transmission cost by absolute MW-km approach (\$)	Transmission cost by MW-km approach (\$)	Bus number
103,484	89,461	1
42,039	16,372	2
64,546	64,457	3
48,362	48,230	4
47,675	46,694	5
12,031	4,611	6
48,724	48,216	7
69,528	69,144	8
34,545	33,977	9
26,043	25,724	10
36,676	36,267	11
24,911	24,577	12
558,565	507,728	Sum

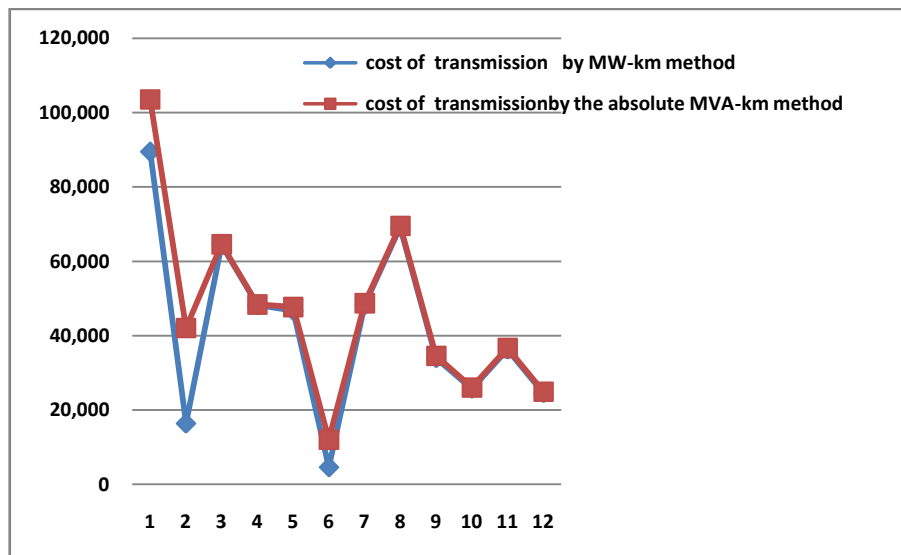

Figure 3. The comparison of cost of transmission of participants by MW-km and absolute MVA-km approaches

As shown in table 5, the total transmission costs that is delivered from network participants at MW-km method is US \$ 507,728 and at absolute MVA-km method is US \$ 558,565. As a result, the total cost of transmission of absolute MVA-km method is higher about 50,837 \$ (about 10%) than the MW-km method. As shown in figure 3,

transmission cost calculated by MVA-km method, is greater than the calculated transmission cost by MW-km method, because MVA-km method use from apparent power for calculating the cost of transmission, which is always greater than or equal active power. In the MW-km method, transmission cost is calculated based on the active power and in MVA-km method is calculated based on lines apparent power flow. Since capacity of transmission lines is determined based on the its apparent power flow, using of MW-km method makes the received cost of network participants be less than actual amount of network lines capacity. As a result, the MW-km method may be disable to cover the costs of investment in long-term and therefore not compensated the costs of transmission network. In case if just the active power is used to calculate the costs, the obtained cost don't indicate the exact amount of the cost of using participants of network lines and allocated costs are not fair.

4.4. Comparison of the results of the three approaches that use MVA-km.

In this section, the results of the simulation of the three proposed approaches for MVA-km method are presented and the results are compared together. So is investigated effect of counter-powers on the cost of transmission. The cost of calculated transmission by the three absolute, inverse and zero counter-flow MVA-km approaches are presented in Table 6 and Figure 4.

As shown on table 6, and is expected, the transmission cost of first approach is maximum amount and the transmission cost of second approach is minimum amount. The calculated transmission cost by first approach, is 558,565 \$ that is maximum, because always use from the absolute value of apparent power and don't consider the direction of powers flow. In case lines inverse powers flow, in second approach, not only participants don't pay any cost but also cashed out cost. Then it's expectable that the transmission cost of second approach be minimum. Its cost is 208,034 \$. In the third approach, unlike the first and the second approaches, don't pay or cashed out any cost for lines counter power flow, then, the transmission cost of the third approach is less than first approach, but is more than the second approach, the cost of third approach is 398,796 \$.

The cost of network participants transmission in the three different approaches, were compared in Figure 4. As can be seen, costs of some participants, including participants at the buses 6, 10 and 12, at the first and third approaches, have no significant difference. While some other participants, such as participants at the buses 2 and 8, the cost that is calculated on different approaches have huge difference together.

Table 6. The calculated transmission cost by the approaches of MVA-km method

Approach 3: zero counter-flow MVA-km	Approach 2: inverse MVA-km	Approach 1: Absolute MVA-km	Bus number
89,009	70,724	103,484	1
26,493	-193	42,039	2
43,051	20,625	64,546	3
27,197	4,729	48,362	4
38,392	24,915	47,675	5
8,563	2,585	12,031	6
31,927	13,245	48,724	7
36,876	3,147	69,528	8
24,287	12,480	34,545	9
22,992	18,914	26,043	10
27,342	17,135	36,676	11
22,666	19,727	24,911	12
398,796	208,034	558,565	sum

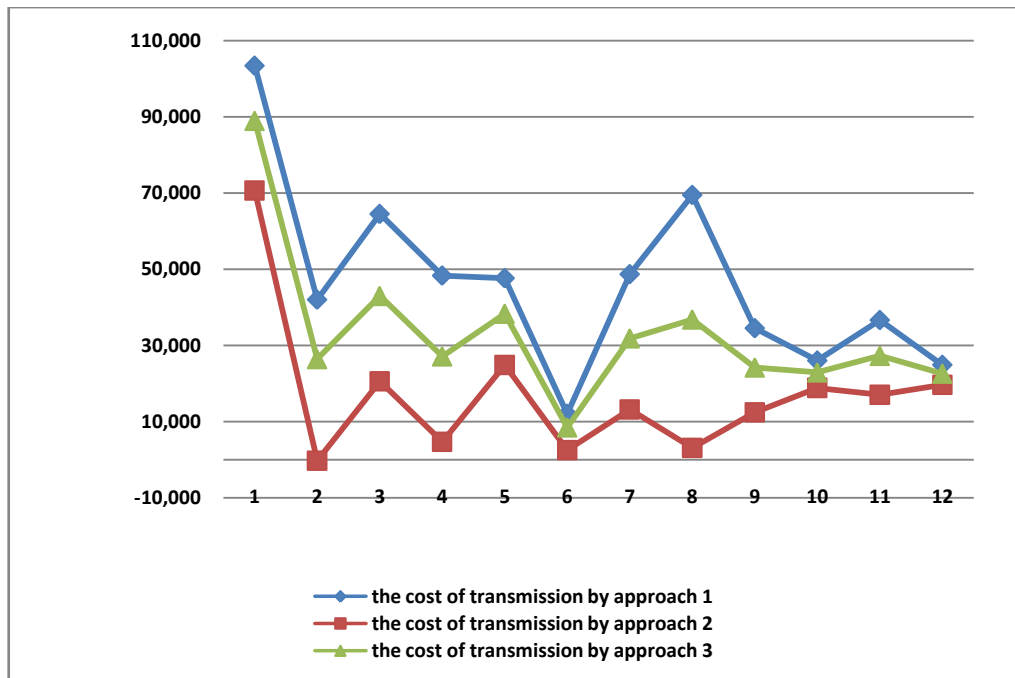

Figure 4. The comparison of costs of participants transmission by the approaches of MVA-km method

For detailed review, consider the participant located in the second bus this participant should pay, in approaches 1 and 3, 42039 \$ and 26493 \$ respectively, while on third approach, not only pay any cost, but also receive 193 \$. This indicates the position of this participant in the network is such that its productive active and reactive power, is in the opposite direction of lines power flow and therefore generation of power by this participant, not only don't occupy the lines capacity but also can reduce lines power flow and it can open the capacity of lines for using by other participants. So if we want examine the approaches of MVA-km from fairness perspective of pricing schemes of transmission, the second approach is most fairly and after that, third approach is best. On the other hand, if we look from the perspective of returning investment costs of the transmission network, the first approach, second and third greatest return on investment, and would make extra motivation for new investment in the transmission network. From the perspective of investment in the transmission network, may be unreasonable that payment cost to participants that cause extra power in network and in the long term, wouldn't cause compensation of investment costs of some lines. In general, it can be concluded that the first approach has the greatest return on investment, but the most unfair practice. The second approach is the most fair, but makes the lowest return on investment. The third approach, have positive characteristics of the other two approaches, and can be a more reasonable option for selection by policy of electricity market. Prefer one of this method over other approaches, need detailed study of variable and fixed costs of transmission lines for each network separately, so that be able to select best approach for calculating of transmission cost.

5. Conclusion

In this article, for pricing of transmission services, used MVA-km and Zbus methods. Also to evaluate the effect of lines counter power, three new approaches were introduced for MVA-km method and were presented necessary equations. Simulation of proposed method was done on the test network of 12 Bus. Results of MW-km method were compared with absolute MVA-km method. The results of this comparison showed that the received transmission cost by the MVA-km method was more and caused more compensation of costs of transmission investments and caused extra motivation to new investment. Also due to the occupation of capacity of lines by the apparent power and not by active power, transmission pricing by MVA-km method is fairer. Then were compared the results of the three approaches that were proposed for MVA-km method. The result of this comparison showed that although absolute MVA-km approach makes more investment returns, but this approach is not fair. Also found that inverse MVA-km approach caused the highest investment return, but not fairly. Finally, it was shown that zero counter-flow MVA-km approach, with the benefits of the other two approaches, can be better choice for the pricing of transmission network.

References

- [1] Daniel S. Kirschen, Goran Strbac, *Fundamentals of Power System Economics*, John Wiley & Sons, Ltd, 2004.
- [2] S. Stoft, *Power System Economics; Designing Markets for Electricity*, IEEE Press, 2002.
- [3] Tarjei Kristiansen, "Comparison of transmission pricing models", *International Journal of Electrical Power & Energy Systems*, Vol. 33, May 2011, pp. 947-953.
- [4] Garg, N.K., Palwalia, D.K., Sharma, H., "Transmission pricing practices: A review", *Proceeding on Nirma University International Conference on Engineering (NUICONE)*, 2013, pp. 1-6.
- [5] M. Cannella, E. Disher, R. Gagliardi, "Beyond The Contract Path: A Realistic Approach to Transmission Pricing", *The Electricity Journal*, Vol. 9, Iss. 9, 1996, pp. 26-33.
- [6] F.Hussin, M.Y.Hassan, K.L.Lo, "Transmission Congestion Management Assessment in Deregulated Electricity Market", *Proceeding on Conference on Research and Development (SCORED)*, Selangor, MALAYSIA, Jun. 2006, pp. 1-6.
- [7] Delberis A. Lima, Antonio Padilha-Feltrin, Javier Contreras, "An overview on network cost allocation methods", *Electric Power Systems Research*, Vol. 79, May 2009, pp. 750-758.
- [8] Murali, M., Kumari, M.S., Sydulu, M., "A comparison of embedded cost based transmission pricing methods", *Proceeding on International Conference on Energy, Automation, and Signal (ICEAS)*, 2011, pp. 1-6.
- [9] Sarfati, M., Hesamzadeh, M.R., "Pricing schemes for dealing with limited transmission capacity - A comparative study", *Proceeding on IEEE Power and Energy Society General Meeting (PES)*, 2013, pp. 1-5.
- [10] M.D. Simoni, A.J. Pel, R.A. Waraich, S.P. Hoogendoorn, "Marginal cost congestion pricing based on the network fundamental diagram", *Transportation Research Part C: Emerging Technologies*, Vol. 56, Jul. 2015, pp. 221-238.
- [11] Tarjei Kristiansen, "Comparison of transmission pricing models", *International Journal of Electrical Power & Energy Systems*, Vol. 33, May 2011, pp. 947-953.
- [12] Anusha Pillay, S. Prabhakar Karthikeyan, D.P. Kothari, "Congestion management in power systems – A review", *Electrical Power and Energy Systems*, Vol. 70, Sep. 2015, pp. 83–90.
- [13] Savagave NG., Inamdar HP., "Price area congestion management in radial system under de-regulated environment – a case study", *International Journal of Electrical Engineering & Technology (IJEET)*, Vol. 4, Jan.–Feb. 2013, pp. 100-108.
- [14] Orfanos, G.A., Tziassiou, G.T., Georgilakis, P.S., Hatziaargyriou, N.D., "Evaluation of transmission pricing methodologies for pool based electricity markets", *Proceeding on IEEE Trondheim PowerTech*, 2011, pp. 1-8.
- [15] Milos Pantos, Ferdinand Gubina, "Ex-ante transmission-service pricing via power-flow tracing", *International Journal of Electrical Power & Energy Systems*, Vol. 26, Sep. 2004, pp. 509-518.
- [16] Nojeng, S., Hassan, M.Y., Said, D.M., Abdullah, M.P., Hussin, F., "Improving the MW-Mile Method Using the Power Factor-Based Approach for Pricing the Transmission Services", *IEEE Transactions on Power Systems*, Sep. 2014, pp. 2042 – 2048.
- [17] Kharbas, B., Fozdar, M., Tiwari, H., "Transmission tariff allocation using combined MW-Mile & Postage stamp methods", *Proceeding on IEEE PES Innovative Smart Grid Technologies - India (ISGT India)*, Dec. 2011, pp. 6-11.
- [18] Kilyeni, S., Pop, O., Slavici, T., Craciun, C., Andea, P., Mnerie, D., "Transmission cost allocation using the distribution factors method", *Proceeding on IEEE Mediterranean Electrotechnical Conference MELECON*, 2010, pp. 1093 – 1098.
- [19] Conejo, A.J., Contreras, J., Lima, D.A., Padilha-Feltrin, A., "Zbus Transmission Network Cost Allocation", *IEEE Transactions on Power Systems*, Feb. 2007, 342 – 349.
- [20] Kharbas, B., Fozdar, M., Tiwari, H., "Comparative assessment of MW-mile and MVA-mile methods of transmission tariff allocation and revenue reconciliation", *Proceeding on IEEE Power and Energy Society General Meeting (PES)*, Jul. 2011, pp. 1-5.
- [21] Oana Pop, Florin Solomonesc, Constantin Barbulescu, Stefan Kilyeni, "Allocation of Transmission Cost for Reactive Power Using System Matrices Method", *Proceedings on International Universities' Power Engineering Conference (UPEC)*, 2011, pages 1-6.

- [22] Kilyeni, S., Pop, O., Prostean, G., Craciun, C., “Transmission cost allocation based on power flow tracing using Z bus matrix”, Proceeding on International Conference on Harmonics and Quality of Power (ICHQP), 2010, pp. 1-6.
- [23] Almaktar, M.A., Hassan, M.Y., Abdullah, M.P., Hussin, F., Majid, M.S., “Charge of transmission usage and losses in pool electricity market”, Proceeding on International Power Engineering and Optimization Conference (PEOCO), 2010, pp. 557 – 562.
- [24] Ray D. Zimmerman, Carlos E. Murillo-Sanchez, “Matpower 5.1 - User's Manual”, Power Systems Engineering Research Center (Pserc), Mar. 2015.