



Protection of Telecommunication Systems in Electric Power Facilities from Electromagnetic Pulse (EMP).Part. 2.

Vladimir Gurevich, Ph. D.
Israel Electric Corp., Israel, Haifa

Abstract

A communication system installed at an electric power facility performs the critical role in data acquisition and transmission, remote measuring and control, and communications. At the same time, it is most sensitive and the least protected from the high-altitude electromagnetic pulse (HEMP) amongst the wide variety of other critical electric and electronic systems used at the power facilities. Such a situation should not be considered as normal; instead it requires the appropriate measures to be taken. This article is an extension to the discussion of this problem started in the previous article [1]. It describes the common technology and element basis used for protection of communication system equipment.

Keywords: Telecommunication systems, High Altitude Electromagnetic Pulse, HEMP, Protection elements

I. INTRODUCTION

The electronic equipment used in a power sector is specifically complex and diversified – it consists of a large number of types of apparatus enclosed in the special communication cabinets, see Fig. 1.

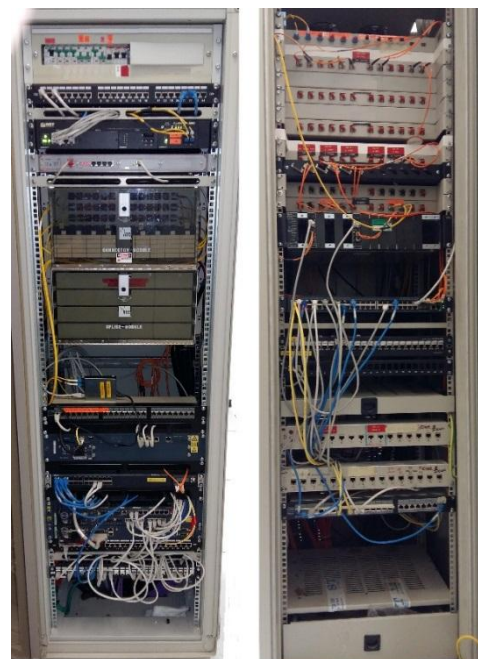

Fig. 1a. Communication cabinet



Fig. 1b. MOSCAD-RTU cabinets



Fig. 1c. Digital Distribution Frame (DDF) and Main Distribution Frame (MDF). Left – installed in the cabinet, right – wall-mounted open panel.

Upon examination of this cabinet (see Fig. 1), it is obvious that there is a problem of protection of the electric power facilities communication system.

It is clear that the new communication systems should be designed on the optoelectronic and fiber optical communication lines (FOCL) only, while all the electronic equipment should be enclosed into the specially protected cabinets, and powered from the protected power supplies through the protected cables.

Coincidentally, the existing equipment (see Fig. 1) designed and installed with disregard for HEMP sustainability requirement, creates a much more complicated problem. The problem cannot be solved by replacing the copper cables with the fiber optic cables equipped with the special additional converters, since in such a case the sensitive electronics remain installed in the glass door cabinets, providing zero protection against the electromagnetic pulse. Such cabinets are powered from the unprotected power supplies, have dozens of entering cables (some of such cables have no shields), etc. Plus, it is hardly possible, if possible at all, and very expensive to replace with the fiber optic cables the whole telemetry system, as SCADA (Supervisory Control and Data Acquisition) contains numerous RTU (Remote Terminal Unit) sensors distributed over a large area. Thus, other means must be used to ensure the protection of existing communication systems.

HEMP protection means may be categorized as follows:

- 1) Special elements protecting the apparatus sensitive inputs;
- 2) Common technology for apparatus protection provided through the cabinet design, electric power supplies, grounding system, etc.

The first one was previously discussed in [1]. This article describes the common design concept and the technologies aimed to increase the survivability of the communication system.

II. THE CONCEPT FOR COMMUNICATION APPARATUS PROTECTION

The communication system is the one component of the electrical complex providing the electric power generation, transmission and distribution. Thus, the common approach taken to the all other components and parts of this complex can be taken to this component, too: only critical parts of the apparatus located at critical facilities and providing critical functions, mandatory for making energy generation, transmission or distribution possible, should be HEMP-protected. The facilities to be protected should be determined by the power facility staff beforehand and included in the special reconstruction plan.

The determination of critical parts of equipment can be really problematic, as many types of such equipment are used to maintain a service of both critical and non-critical power facilities at the same time. In fact, several inputs of the same multichannel device can be connected to the critical external electric chains, while the remaining can be connected to noncritical external electric chains. If only the critical inputs are protected, the multichannel electronic device can become fully inoperable upon the electromagnetic pulse penetrating into the device through the unprotected input. Thus, critical and noncritical electric chains must be separated into the different groups, and each group should be provided with the separate communication device. This problem is the most relevant to SCADA systems containing many cabinets and electronic modules (e.g. MOSCAD, see Fig. 16), processing and transferring the signals coming from the remote telemetry sensors (RTU) to the central control room. Several of these signals are very important, while others can be temporarily ignored in case of emergency after the HEMP impact. Thus, all important RTU chains must be switched to the inputs of the electronic module assigned as critical, and the modules themselves must be located in the cabinets that determined as critical. Meanwhile, the protection of the most critical RTU sensors is a separate challenge. Measures for protection of such cabinets are further considered in the next chapters.

III. RECONSTRUCTION OF CABINETS CONTAINING ELECTRONIC APPARATUS

As mentioned above, many communication cabinets are equipped with glass doors allowing free passage of electromagnetic radiation, therefore the reconstruction of the critical cabinets should first and foremost start with the doors. New doors should not contain a large non-electrical conductive section allowing the gating of the electromagnetic pulse.

The market proposes a relatively wide range of conductive clear glass (or, more precisely, glass with a top conductive layer) from different manufacturers, such as LatechTM, Visiontek Systems, Holland Shielding Systems B.V., Techinstro, and many others. The glass is produced by dispensing the special additions into its top layer. Basically, several types of alloying additions are used: indium tin oxide (ITO), fluorine-doped tin oxide (FTO),

or more rarely – doped zinc oxide. Also, the polymeric conductive panels based on polyacetylene, polyaniline, polypyrrole, polythiophene, etc. are produced [2].

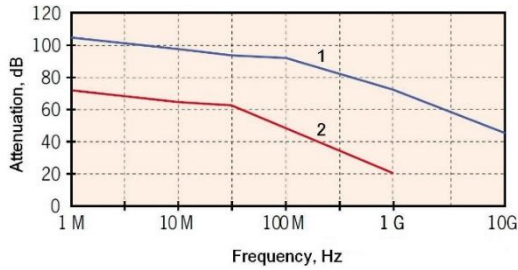

Fig. 2. Shielding effect of glass with copper grid interlayer (1) and conductive top layer glass (2).

A triplex glass consisting of the internal layer made of thin copper grid manufactured by Holland Shielding Systems B.V., sees Fig. 2, demonstrates the best shielding effect.



Fig. 3. Electrical conductive coatings, paints, and sprays

Alternatively, a different conductive coating, paints, sprays (also widely available in the market), see Fig. 3, can be put onto the glass door.

Another alternative is a complete replacement of glass doors with metal doors.

Additionally, to improve the electronics cabinet protection the special conductive rubber seal can be installed along the door perimeter, see Fig. 4.



Fig. 4. Door conductive rubber seal

If the cabinets have ventilating jalousie, they must be equipped with the special honeycomb panels, see Fig. 5, consisting of a set of metal tubes with a special diameter-to-length ratio (so-called “below cutoff waveguide”) to pass through the air flow, but preventing the electromagnetic waves penetration.

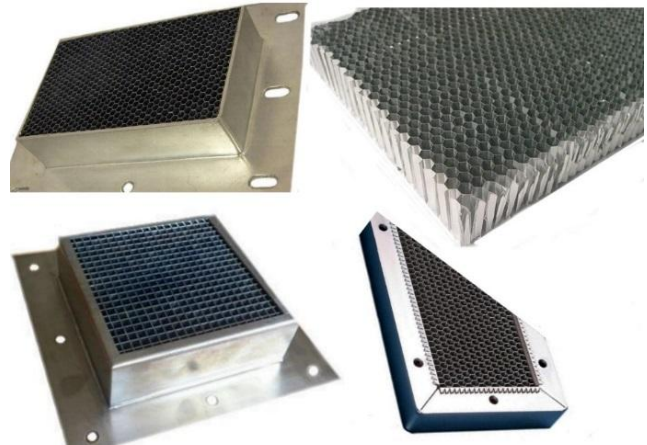

Fig. 5. Ventilating honeycomb panels

In addition to the above-mentioned measures, it is advisable to split the internal space of the cabinet into the several levels separated with the aluminum separating panels containing the minimum number of cable openings (cutoffs).

The above measures for improving the communication cabinet’s sustainability to electromagnetic pulses can also be applied fully to the power supply equipment cabinets. Usually, such cabinets containing battery charges, converters, etc., do not have any door at all and are equipped with numerous ventilating jalousies.

IV. ENHANCEMENT OF THE CABINET CABLE ENTRIES

Many types of communication cabinets are not equipped with the solid metal floor and have large open sections used to entrance a large number of cables bundled into the common harness, see Fig. 6.

Such harnesses contain both shielded and non-shielded cables, high-frequency signal cables, DC analog signal cables, and DC power supply cables. Apart from the mutual interference between the cables, the re-emission from the cables and from it shields the external area induced electromagnetic field into the cabinet interior also shows up.

Thus, that even inside the cabinet which is tightly protected with the above measures, the internal electronic equipment remains exposed to the electromagnetic pulse impacts. Thus, it is not sufficient to enhance the cabinet design itself and the cables entering the cabinet should also be considered. The question at issue is that it is not possible to find any single and common concept of protection suitable for all cables as they transmit different signal types.



Fig. 6. Cable harnesses entering the communication cabinets through the floor opening

Thus, the first step should include the separation of the common harness into the different harnesses grouped by the signal type, and the separate shielding of each cable group using the applied flexible shield containing the conductive cloth with the longitudinal zipper-type snap, or by wrapping the electrical conductive tape with a glue layer around each separate cable harness, see Fig. 7.



Fig. 7. Flexible applied shield with zipper-type snap containing the conductive cloth (top), and different conductive tape types based on copper, aluminum and graphite, and glue layer (bottom).

The cabinet floor openings at the cable entry points should be tightly closed with the conductive cloth, see Fig. 8. If the openings are large, the metal grid should be installed under the cloth. to reinforce it.



Fig. 8. Conductive clothes

The DC power supply cable should be equipped with the high-frequency chokes cut into the plus and minus wire, see Fig. 9. Such chokes are small in size and must be installed at the cabinet cable entry point (i.e. on the cabinet floor) under the conductive cloth. The chokes have very low DC resistance (milliohm) and high impedance for a short electromagnetic pulse.

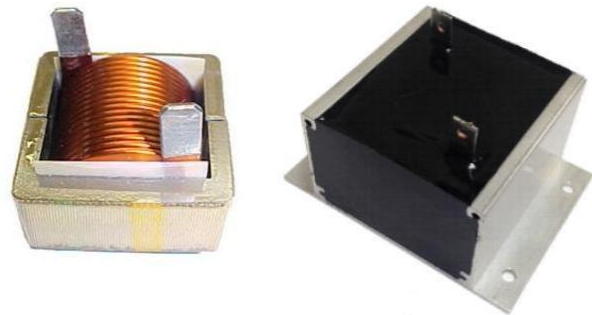

Fig. 9. Chokes manufactured by CWS with a helical coil and a core made of the special alloy attenuating the electromagnetic pulse in the power supply cable. Left – open, right – encapsulated in epoxide compound

The inductance of such chokes required to provide the effective attenuation is calculated considering its decrease under the DC current flow.

The low-frequency signal cables, (kHz range) along with the analog DC signal (4–20 mA) cables, should be protected by the dismountable ferrite beads that do not require cable cutting up, see Fig. 10.



Fig. 10. Dismountable ferrite beads

The beads should be installed on the point where the cable enters the cabinet, such as on the cabinet floor and under the conductive cloth. The bead features and selection are described in [3].

V. RECONSTRUCTION OF GROUNDING SYSTEM OF CABINETS CONTAINING THE ELECTRONIC APPARATUS

Problems of a conventional grounding system of electronic apparatus, installed into the electric cabinets, and the special aspects of a grounding system upon the HEMP are detailed in [4].

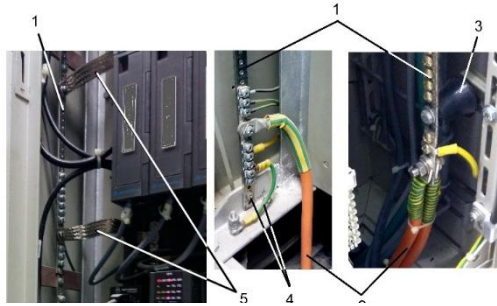

Fig. 11. Design of communication system cabinet grounding 1 – potential equalizer bar; 2 – external grounding system cable; 3 – insulator insulating the potential equalizer bar from the cabinet body; 4 – elements connecting the potential equalizer bar with the cabinet body; 5 – flexible links connecting the electronic devices enclosures with the potential equalizer bar.

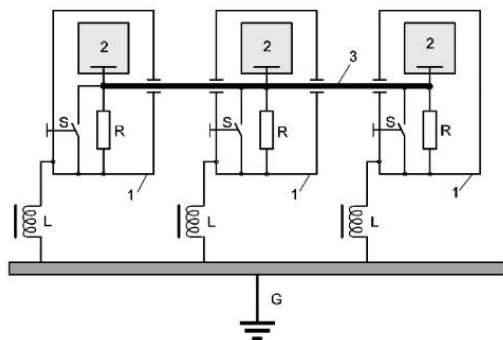

Fig. 12. Proposed grounding system: a special floating ground [4]. 1 – metal cabinets; 2 – electronic apparatus; 3 – large enough flexible insulated shielded cable forming the insulated local zero potential area (so-called local ground): R – high-resistance high-voltage resistors; S – end switches connecting the local ground with the external ground when the cabinet door is open; L – chokes; G – external grounding system.

According to the recommendations listed in [4], the enhanced communication cabinet grounding system should be made as a special floating ground, see Fig. 12.

Unfortunately, these special aspects are hardly ever considered. Often, the cabinets containing the identical communication apparatus have grounding systems of very different design (e.g. potential equalizer bars connection, see Fig. 11). From the point of view of common sense, such differences are hard to explain. Also, the same goes for the rationale for isolating these potential equalizer bars from the cabinet, as the electronic metal enclosures are mounted on the cabinet metal elements directly, without any insulation at one side, and these enclosures are bounded to the insulated equalizer bars at the other side.

VI. RECONSTRUCTION OF THE OPEN DDF AND MDF PANELS

If DDF and MDF panels (see Fig. 1c) are open and installed directly on the wall, they require special

measures to be taken to ensure the protection against an electromagnetic pulse. One of the options is to install special aluminum two-piece shields: the plate being slightly bigger than the wall-mounted DDF and MDF panels located behind the plate, and a flanged box enclosing the panel from the front. The crevice-free joint between the box and the plate is made as the metal-metal contact or using the conductive rubber spacers. All low-frequency cables should be protected with cheap and rather effective ferrite beads, while the high-frequency twisted pairs of critical cables should be protected with the special protecting elements built based on TVS-diodes, see [1]. These protection elements are installed on the small panels and are connected in parallel to the same DDF and MDF panel connectors using the twisted pair conductors.

VII. PROTECTION OF POWER SUPPLY SYSTEM

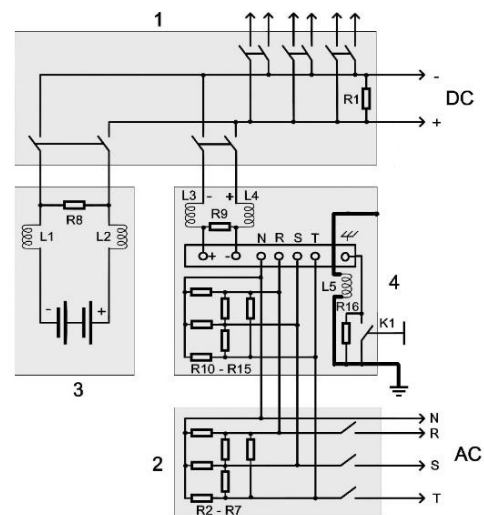

Fig. 13. Communication apparatus power supply system. 1 – DC distribution board; 2 – AC distribution board; 3 – battery bank; 4 – battery charger (sometimes containing the integrated converter); L1 – L4 – protective chokes; R1 – R15 - varistors; L5, R16, K1 – grounding system elements such as the special floating ground

The protection of a communication apparatus power supply is performed by the traditional methods using varistors and chokes, see Fig. 13.

Such power supply system design concepts are all-pervading and were described earlier in [5]. In the relatively low-power system supplying power to communication apparatus, it is advised to use chokes and varistors (or TVS-diodes) enclosed in cases designed for installation inside the cabinets on the standard DIN-rail, see Fig. 14.



Fig. 14. 36A and 100A chokes manufactured by Citel (top) and varistors (TVS-diodes) of different brands installed in the cases designed specifically for in-cabinet installation on standard DIN-rail (down)

In addition to the power supply protection measures explained above, the small diesel generator (3–5 kW), with the premounted externalized exhaust pipe and the compact battery charger, see Fig. 15, should be installed in the room where the battery charger is located (or in close proximity). Such a compact diesel generator with the compact battery charger should be disconnected from all external electric circuits and put into the closed aluminum container.



Fig. 15. Compact battery charger 4 kW, 0 – 250VDC

Such a redundant power source is required on the chance that the external AC power source feeding the whole communication system is damaged by the high-power HEMP.

VIII. RECONSTRUCTION OF THE FACILITY (ROOM) CONTAINING THE CRITICAL KINDS OF COMMUNICATION SYSTEMS

Generally speaking, many external cables enter the facilities and they may contain unprotected windows. It is clear that the facility designed and built as unprotected cannot be fully protected. However, it is possible to significantly attenuate the level of electromagnetic radiation entering into the facilities through the cables, the windows, and the doors. In order to do this, the cables entering the facility must run in the special solid metal cable trays starting immediately from the penetration points, while the windows and the doors must be shielded

in the same manner as the cabinet glass doors, or be fully enclosed with aluminum panels or the conductive curtains.

IX. CONCLUSION

The described above technology of protection of the most sensitive and vulnerable power sector systems, such as communication against HEMP is quite affordable and easily realizable if used along with the previously described methods of protection of electronics sensitive inputs. The market proposes a wide range of inexpensive elements and materials available for the realization of this concept. Proposed technical solutions and recommendations are mainly aimed at the reconstruction of current systems, but may be partly used for designing new systems built on optoelectronic and fiber-optic communication lines (FOCL).

REFERENCES

- [1] Gurevich, V. Protection of Telecommunication Systems in Electric Power Facilities from Electromagnetic Pulse (EMP). Part. 1. – Innovative Engineering and Physical Sciences (IEPS).
- [2] Skotheim, Terje A. Reynold, John - Handbook of Conducting Polymers, CRC Press, 1998.
- [3] Gurevich V. The problem of Correct Choice of Ferrite Beads. – Electrotechnics & Electromechanics, 2016, No. 2, pp. 71- 73.
- [4] Gurevich V. The Issues of Electronic Equipment Grounding at the Power Facilities. - International Journal of Research Studies in Electrical and Electronics Engineering (IJRSEEE) Vol. 3, Issue 1, 2017, pp. 11-19.
- [5] Gurevich V., Facilities Ensuring Substation Direct Current Auxiliary Power System Survivability under Electromagnetic Pulse (HEMP). Part 1. Stationary Substation. – International Journal of Electrical and Electronics Research, 2017, Vol. 5, Issue 3, pp. 6 – 12.