



Protection of Telecommunication Systems in Electric Power Facilities from Electromagnetic Pulse (EMP). Part. 1.

Vladimir Gurevich, Ph. D.
Israel Electric Corp., Israel, Haifa

Abstract

Telecommunication systems of electric power facilities play important role in data transmission, telemetry, remote control and communication. At the same time, these systems are the most sensitive to, and the least protected from, High Altitude Electromagnetic Pulse (HEMP), compared to other important electric and electronic systems used in the electric power industry. This situation cannot be perceived as normal and thus calls for corresponding actions. Unfortunately, renowned technical means are often very expensive, and regardless of advertisement, claims they do not always ensure reliable HEMP-protection of telecommunication systems. An analysis of the situation for the problem is presented in this article.

Keywords: Telecommunication systems; High Altitude Electromagnetic Pulse; HEMP; Protection elements.

I. INTRODUCTION

The High Altitude Electromagnetic Pulse of a nuclear explosion (HEMP), which creates a pulse of electric field with the density of up to 50 kV/m at the ground surface, is a powerful affecting factor aimed at causing the country's infrastructure to be out of operation. Military leaders of various countries perceive HEMP as a very efficient and perspective type of non-lethal weapon. On the one hand, high efficiency of infrastructural impact is determined by the wide spread of microelectronic and microprocessor-based equipment in all types of modern systems (primarily those of electric power industry), whereas on the other hand, this equipment is completely unprotected in civil sectors [1].

Among various systems used in the electric power industry, the telecommunication system, which includes data transceiving, telemetry, remote control and communication systems, features the highest level of susceptibility to HEMP. In fact, modern sophisticated electronic telecommunication equipment uses very low (compared to other electric systems used in the electric

power industry) voltages (not exceeding 3.5 - 5V). Thus, it has a low level of insulation of all the input and output circuits. That is why usual EMC standard requirements to low-voltage electric and electronic equipment that stipulate (among other things) testing with high-voltage pulses (2 and 4 kV) are not applicable to telecommunication ports, if they are available in these devices. This provision is included in all the standards that stipulate these tests.

Telecommunication channels of the electric power industry are used to transfer real-time data regarding emergency modes between digital protection relays, and to perform remote control of high-voltage circuit breakers that determine the status of electric grid. Thus, the relevance of HEMP-protection of telecommunication systems becomes obvious.

In the majority of situations, the issue was resolved due to conversion from galvanic-coupled circuits and copper-conductor cables to fiber-optics communication line (FOCL), nevertheless, the problem of protecting multiple microprocessor based terminal devices that convert electric signals into optical and vice versa is still relevant. However, there are electric power facilities, where telecommunication systems equipped with highly-sensitive electronic devices with galvanic-coupled circuits are still employed. This surfaces a question regarding the modes of re-designing of such a system in order to improve the level of its protection from HEMP.

There are some common measures to improve HEMP-resistance of equipment. These do not depend on the selected mode of re-designing. Predominantly, these measures deal with upgrading of electronic equipment cabinets that provide efficient protection of internal equipment from electromagnetic emission. Additionally, they ensure protection and backup of the power supply system. These measures and the means of their adoption were discussed earlier [2]. This article discusses the technical means that protect data transmission channels.

An obvious solution would be to equip the existing telecommunication equipment with optical links that consist of converters of incoming and outgoing electric signals into optical signals and vice versa, and to transfer

these signals between the converters via a fiber-optic cable. Various converters of electric signals into optical, and vice versa, suitable for telecommunication systems are readily available in the market (Fig. 1). Thus, the problem of protection of data transfer channels using these converters can easily be solved.



Fig. 1. Various converters of electric signals into optical, and vice versa, suitable for telecommunication systems.

II. THE PROBLEMS WITH TRADITIONAL WAYS AND ELEMENTS FOR PROTECTION THE EXISTING TELECOMMUNICATION EQUIPMENT WITH GALVANIC COUPLING VIA COPPER-CONDUCTOR CABLES

It is more challenging to protect the existing telecommunication equipment with galvanic coupling via copper-conductor cables. Standard HEMP-protection (stipulated by standards and offered by multiple manufacturers) of this equipment is represented by special filters that efficiently suppress electric signals above a certain frequency level. However, [3] suggests that the use of special expensive filters to suppress a single short pulse lasting for parts of microseconds is absolutely unnecessary. Additionally, the frequency range of many modern communication and data transfer systems falls within the HEMP spectrum, which should be suppressed by these filters, whereas the filters themselves are often represented by low-voltage devices, which do not allow application of high-voltage pulses to their input. Thus, telecommunication equipment needs to be protected from the impact of high-voltage pulse only.

There are devices incorporating the elements that significantly reduce their impedance in case of higher (compared to nominal) voltage applied to them. They protect electronic equipment from high voltage pulses and include:

- Gas Discharge Tubes (GDT);
- Metal Oxide Varistor (MOV);
- Thyristor Surge Suppressor (TSS; Sidac);
- Transient Voltage Suppressor (TVS-diode).

Comparison of the best in class (based on our survey) elements based on the aggregate of key parameters that make them appealing for use in telecommunication systems is provided in Table 1.

Response time (reaction time) of the element is one of the most important indicators, which is rarely indicated in catalogs explicitly. This is connected with many reasons, in particular, with the dependence of this time on the speed of voltage pulse rise and on the shape and the length of leads of specific elements. If this time is indicated in catalogs, it does not make a lot of sense as the manufacturers often use the semi-product (in fact, they use the material, from which the element is manufactured without leads and covering) to reduce it. Furthermore, the response time of the element in real circuits will depend on the parameters of a circuit that it is protecting. It is known, however, that TVS-diodes feature the best response time (several nanoseconds).

Table 1. Some main parameters of protective elements of different kinds				
Parameter \ Kind (group) of element	GDT	MOV	TSS	TV S
Best type of element in the kind (group)	2020-15T	V05E1 1P	TISP 4011H1 BJ	S03-6
Max. Operating voltage, V	-	11	5.25	6
Min. Activation voltage, V	60 (650)	18	10.5	6.8
Residual (clamping) voltage, V	52	36	3	15
Max. Pulse power, W	-	-	-	2800
Max. Pulse current, A (2/10 μs)	4000	500	500	150
Reaction time	-	-	-	-
Capacitance between electrodes, pF	2	1300	110	25

They are followed by thyristor surge suppressors with their dozens of nanoseconds, followed by varistors with response time of several dozens of hundreds of nanoseconds. The last in this row are gas discharge tubes (GDT) with a response time of 0.2 – 0.5 ms (the rise time of the HEMP voltage pulse is several nanoseconds and length of the current pulse amounts to dozens - hundreds of nanoseconds). Other disadvantages of gas discharge tubes include high actuation voltage and residual voltage. Moreover, actuation (gas breakdown) voltage of the lowest-voltage gas discharge tubes increases sharply with the increase of steepness (decrease rise time) of applied voltage pulse.

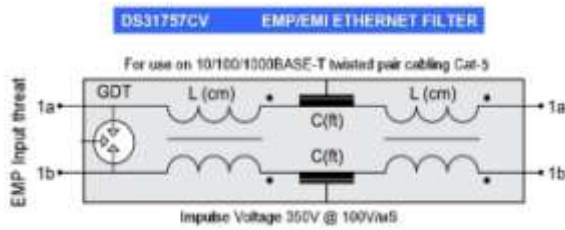

Fig. 2. Circuit diagram of a device protecting Ethernet network from HEMP based on gas discharge tube (GDT) manufactured by MPE Company.

For example, according to IEC 61643-311 [4], the minimum GDT's discharge voltage rises from 75 V to 650 V if the rate of applied voltage increase as 1 kV/μs. obviously, this value will be even higher for HEMP pulse with its high steepness (rate of increase). Now it becomes clear that GDTs themselves cannot ensure protection of electronic equipment from HEMP.

Due to this, various HEMP-protection devices marketed by some manufacturers seem very weird as their main (and often the only) element protecting from over-voltage is represented by GDTs, Fig. 2.

One of the manufacturers explain upon our request that they are aware that GDT cannot provide protection from HEMP, but it is preferable to use these imperfect protecting devices rather than not to use any at all. This proves that we should not rely on promotion brochures only. We need to conduct a thorough analysis of the internal structure of the offered device and the applied hardware components.

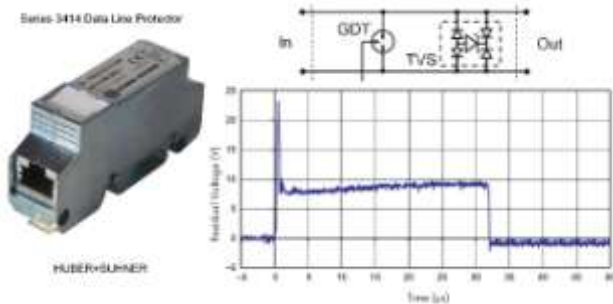

Fig. 3. Design of electric circuit of one channel and actuation oscillogram of Series 3414 protecting device manufactured by HUBER+SUHNER Company [6].

Varistors that are widely used in electric engineering are also not suitable for telecommunication systems, however, the reason is different: they are not suitable due to their high capacitance (for low-voltage elements). High capacitance connected to high-frequency circuits of telecommunication systems results in significant distortion and weakening of a useful signal. Thus, it is not acceptable to use high-capacitance protection elements in these systems. Table 2 shows maximum permissible capacitance values for various signals recommended in [5].

Gas discharge tubes feature the best parameters from the minimum capacitance point of view (i.e. minimum impact on the circuit being protected). This feature, combined with high switching capacity (discharge currents can reach several or even dozens of kiloamperes) does not allow the developers of protecting equipment to disregard them completely. Nevertheless, it is necessary to look for workarounds of using them to protect telecommunication equipment.

Furthermore, according to many manufacturers of protecting devices, this workaround has been found. The idea was to combine high current, but a slow gas discharge tube, with a fast but low current suppressor (Fig. 3).

However, this technical solution is rather puzzling. Transient voltage suppressors (TVS-diode in the diagram) are known to actuate (i.e. switch into conducting low impedance state upon increased voltage pulse impact) much quicker than gas discharge tubes (GDT in the circuit diagram). But upon the TVS suppressor's actuation, the gas discharge tube will never actuate due to low residual voltage on open TVS. This voltage is not enough for gas breakdown in the GDT (minimum GDT breakdown voltage is about 60 V [4]). Lack of conditions for GDT actuation is also confirmed by an oscillogram, which clearly shows that the voltage in this circuit does not ever reach minimum voltage value necessary for GDT breakdown.

Another attempt to solve the problem was made by introducing additional resistors into the circuit (Fig. 4).

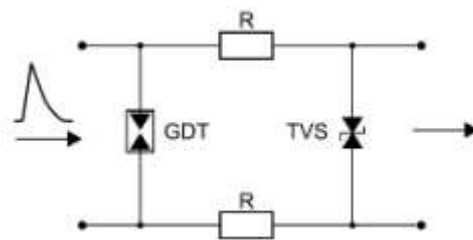

Fig. 4. A circuit diagram of compound two-stage protective device with additional resistors R

The idea of the developers was that when high voltage pulse with high steepness of the leading edge arrives at the input of this device, the first one to actuate would be the TVS, which would limit the voltage amplitude of a device being protected. Furthermore, current flowing through it will result in the voltage drop on R resistors. The total voltage drop on resistors connected in series and the TVS suppressor should be sufficient for GDT breakdown. This will bypass the input of the device after its actuation and take the current off the TVS. Thus, developers expected the device to combine advantages of a TVS (fast response) with high switching capacity of a gas discharge tube, while the total capacitance of a device was expected to remain low. This design became very popular in many various types of protecting devices, manufactured by different companies (Fig. 5).

Similar designs with GDT in the first stage (sometimes with different non-crucial changes and additions) are used in many protecting devices, promoted as special HEMP-protecting tools, such as those of Meteorlabor and many other companies. But deeper analysis of the situation reveals hopelessness of this technical solution of a HEMP protector. This is connected with a short duration of HEMP voltage pulse (up to several dozens of nanoseconds). The action of this short pulse will finish prior to gas discharge of the tube's actuation. Thus, the GDT is not important and the lack, of or its availability, will not affect operation of the protective device.

Some manufacturers use chokes instead of resistors in a diagram depicted in Fig. 4. The idea is to delay the process of voltage rise on a TVS suppressor; bring the moment of its actuation closer to origination of discharge in the gas discharge tube, and thus limit time for heavy current flow through the suppressor. These chokes, featuring high impedance for a short pulse, will also limit the amplitude of current flowing through the TVS. However, the problem is that these chokes will present significant attenuation into a useful high-frequency signal that falls into the megahertz range. Thus this idea is not very suitable for telecommunication equipment.

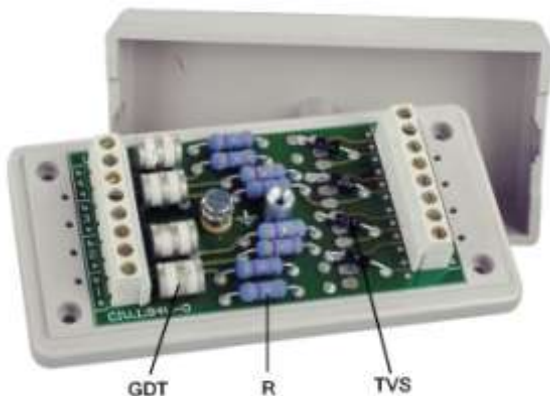

Fig. 5. A sample of compound two-stage protective device designed as shown in Figure 4 manufactured by the industry. GDT – gas discharge tubes; R – resistors; TVS – transient voltage suppressor diode.

Another problem, or more correct – a paradox, is the fact that various measures of equipment protection which weaken the HEMP's impact will result in reduction of the HEMP's pulse current amplitude. Comparatively long cables with copper cores of a small section used in telecommunication systems (i.e. with relatively high impedance) can additionally limit the HEMP's current amplitude. When the current amplitude flowing through the TVS suppressor and low-resistance resistors R (resistance of several ohm) is not sufficiently high, the voltage drop on them may not achieve the value required for GDT breakdown, i.e. 650-700 V and higher (at high rate of voltage increase applied to the gas discharge tube at HEMP impact), while a wider (due to chokes' inductance affect) current pulse will go through the suppressor causing thermal overload of its internal structure and even its destruction.

Unfortunately, these debates cannot be either confirmed or contradicted with the figures due to the lack of real initial data about a HEMP pulse in each specific case and each specific location of equipment, the level of its protection, etc. Also, there are no data about the parameters of each copper couple of telecommunication system's multicore cable running through different intermediate connections. However, a probability of unpredictable behavior of rather expensive devices, which are extensively promoted as a reliable means of protection conforming to MIL-STD-188-125, MIL-STD-461F standards, should alarm the specialists. At the same time, there is a question of how these devices have passed the conformity tests, if according to the above discussion they will not work as intended by their manufacturers. A deeper analysis reveals that there is a pitfall here as well. Indeed, manufacturers of these devices test them using a standard lightning current pulse of 8/20 milliseconds, instead of using a HEMP current pulse of 20/500 nanoseconds, as prescribed by the standards, i.e. the test pulse is flatter and longer. As an excuse, manufacturers state [7] that it is very difficult to simulate a HEMP pulse, and in order to do so special expensive equipment is required. At the same time, generators of a standard lightning current pulse are readily available in the market and they are easy to use. Since the lightning current pulse is much wider than a HEMP pulse, its energy is even stronger than that of the HEMP pulse, thus it creates higher loads for a protecting device. Then they suggest [7] that if a device withstood the test with a more powerful lightning current pulse, it will definitely withstand the short HEMP pulse. But the advocates of this test method bashfully conceal that the behavior of a gas discharge tube under long and short pulse impact will be absolutely different. Gas discharge tubes are reliable under a rather long lightning current pulse featuring a relatively flat leading edge, whereas in case of a much shorter and steeper leading edge of a HEMP, they will not have sufficient time to actuate due to:

- their natural "sluggishness";
- sharp increase of dielectric strength of gas contained in a GDT and consequently due to sharp increase of its breakdown voltage.

III. THE NEW METHOD OF PROTECTION THE EXISTING TELECOMMUNICATION EQUIPMENT

In our opinion, a solution is to use simple, very cheap, non-recyclable, but predictable protecting devices, based on transient voltage suppressors (TVS-diodes) that feature all the parameters necessary for efficient protection of telecommunication systems, such as: fast response time, low capacitance and low actuation voltage. In case of a HEMP impact, the internal p-n-junction of a TVS will breakdown as it is affected by a high current pulse flowing through it, whereas the circuit that it protects will be bypassed (short-circuited). Given the fact that a HEMP event is extraordinary and a pulse is single, non-repeating, this algorithm of protecting the device's operation is quite acceptable as it will protect the equipment from the

HEMP impact, and will allow it to return to operation by just disconnecting the damaged protecting device during the recovery period, which is inevitable in case of global HEMP impact.

The only technical issue is to ensure selective action of the protecting device. In other words, TVS breakdown should occur under a HEMP impact only and not under the impact of other, weaker repeating overvoltage transients.

This selectivity can be achieved primarily by selecting quite powerful TVS, and secondly by limiting the current flow through it by means of a resistor. Analysis of parameters of available TVS with actuation voltage and capacitance values suitable for telecommunication systems, revealed that S03-6 type TVS-diodes (Fig. 6) manufactured by Littelfuse (USA) are the most powerful among others. They are more powerful compared to the TVS of other manufacturers, with the same operating voltage and capacitance values and that allow flowing of pulse currents up to 150 A.

One small chip like this protects a single twisted pair from HEMP of both common (in relation to the reference potential) and differential (between conductors) modes. The price of one element is about 2 US Dollars, however, in the case of wholesale purchase – less than 1 US Dollar.

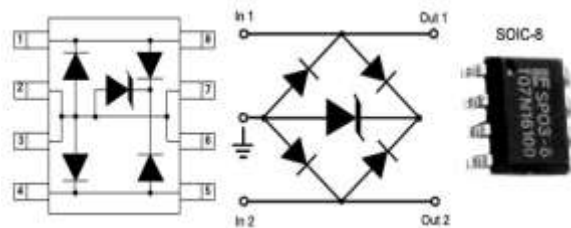

Fig. 6. Transient voltage suppressor diode (TVS) SP03-6 type.

Resistance of a resistor connected with a suppressor in series (see a circuit diagram in Fig. 6, where the resistor is connected in series with each input) should be about 20 Ohm, in order to limit the maximum permissible current pulse flowing through a suppressor in case the pulse transient interference with an amplitude of several kilovolts impacts the protecting device's input. The current-limiting resistors should be non-inductive and should be intended for pulse current of the following types: AW, 234AS, RT818 and others.

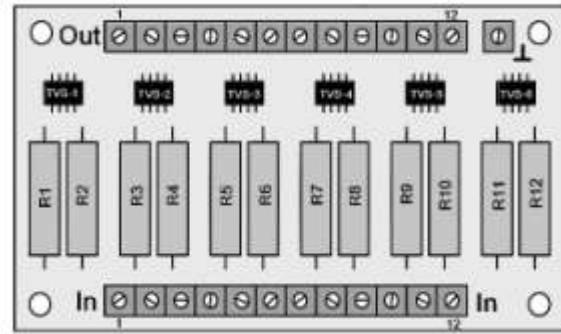

Fig. 7. A drawing of a printed circuit board of the offered protective device for 6 twisted pairs that includes TVS and current-limiting resistors. The circuit board should be coated with a high-voltage varnish.

This design of a protective device makes it very simple in terms of engineering (Fig. 7) and cheap. The same principle can be used to protect the inputs of sensitive equipment connected through a socket (Fig. 8).

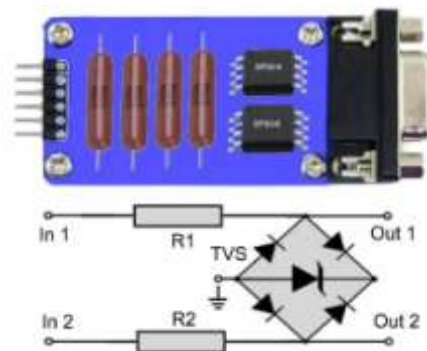

Fig. 8. An example of a simple protecting device for two twisted pairs (for E1 signal) and a diagram of one channel (for single pair) for circuits connected to the equipment via a socket.

These simple devices can be produced by any manufacturer of printed circuit boards at a very affordable price. A range of Chinese companies will quickly produce the required quantity of these devices with excellent quality and at a minimal price. The latter is very important for civil branches of the electric power industry and production sector; as high cost of a HEMP protection is still a key factor that restrains practical adoption of such protection.

IV. CONCLUSION

Analysis of the situation in the field of protecting devices and elements for telecommunication systems showed that expensive devices promoted by their manufacturers fail to provide reliable protection of highly sensitive equipment. It is recommended to use simple, cheap, non-recyclable devices that can be ordered individually by a consumer.

REFERENCES

- [1] Gurevich, V. Protection of Substation Critical Equipment Against Intentional Electromagnetic Threats. – Wiley, London, 2017, 240 p.
- [2] Gurevich, V. Facilities Ensuring Substation Direct Current Auxiliary Power System Survivability under Electromagnetic Pulse (HEMP). Part 1. Stationary Substations. - International Journal of Electrical and Electronics Research (IJEER), 2017, Vol. 5, Issue 3, pp. 6 - 12.
- [3] Gurevich, V. Use of LC-Filters to Protect Equipment from Electromagnetic Pulse: Is It Real Necessity or “Business as Usual”. – International Journal of Research Studies in Electrical and Electronics Engineering (IJRSEEE), 2017, Vol. 3, Issue 1, pp.1 – 7.
- [4] IEC 61643-311 Components for low-voltage surge protective devices – Part 311: Performance requirements and test circuits for gas discharge tubes (GDT), 2 Ed., 2013.
- [5] Clark, M. Transient Voltage Protection Across High Data Rate & RF Lines. – MicroNote 122, Microsemi Corp.
- [6] Catalog HUBER+SUHNER “Lightning Protection”, Edition 2016, pp. 76 – 78.
- [7] Nalhorczyk, A. J. HEMP Filter Design to Meet MIL-STD-188-125 PCI Test Requirements. – IEEE. 10-th International Conference “Electromagnetic Interference & Compatibility”, 26-27 Nov., 2008, pp. 205 – 209.